

SCM..T(SPOSB..EC)

Ball: 440C Stainless steel, heat treated, HRC 56min
precision ground, polished

Body: 304 Stainless steel

Race: PTFE composite or PTFE fabric

Sliding contact surfaces: Steel/PTFE

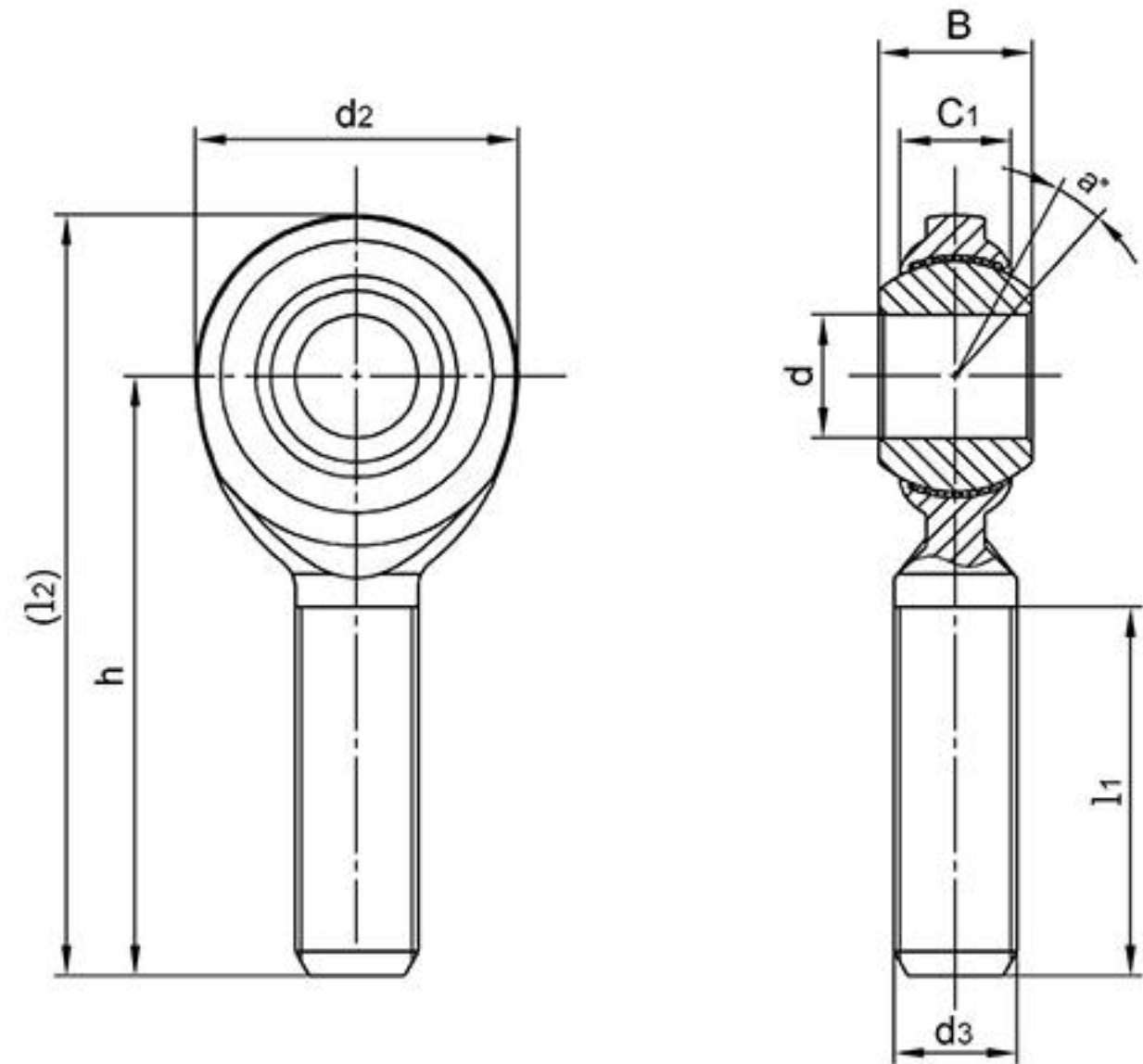

Bearing No.	Dimensions(mm/inches)								Ball dia	a° mis. angle	Load ratings (KN)	weight ≈ kg
	d ^{+0.03} / _{-0.01}	B	C ₁	d ₂	d ₃ UNF-2A	h	l ₁	(l ₂)				
SCM3T	4.826	7.92	5.94	15.88	10-32	31.75	19.05	39.69	11.112	13	4.4	0.013
	0.1900	0.312	0.234	0.625		1.250	0.750	1.562	0.437			
SCM4T	6.35	9.53	6.35	19.05	1/4-28	39.67	25.4	49.2	12.7	18	8.2	0.018
	0.2500	0.375	0.250	0.750		1.562	1.000	1.937	0.500			
SCM5T	7.938	11.10	7.92	22.23	5/16-24	47.63	31.75	58.75	15.875	14	12.7	0.031
	0.3125	0.437	0.312	0.875		1.875	1.250	2.312	0.625			
SCM6T	9.525	12.7	9.11	25.4	3/8-24	49.22	31.75	61.92	18.263	14	14	0.049
	0.3750	0.500	0.359	1.000		1.938	1.250	2.437	0.719			
SCM7T	11.11	14.27	10.31	28.58	7/16-20	53.98	34.93	68.27	20.625	13	17.6	0.068
	0.4375	0.562	0.406	1.125		2.125	1.375	2.678	0.812			
SCM8T	12.7	15.88	11.5	33.32	1/2-20	61.92	38.1	78.58	23.8	12	23.7	0.108
	0.500	0.625	0.453	1.312		2.438	1.500	3.093	0.937			
SCM10T	15.875	19.05	12.29	38.1	5/8-18	66.68	41.28	85.73	28.575	16	25.7	0.163
	0.6250	0.750	0.484	1.500		2.625	1.625	3.375	1.125			
SCM12T	19.05	22.23	15.06	44.45	3/4-16	73.02	44.45	95.25	33.338	14	42.4	0.258
	0.7500	0.875	0.593	1.750		2.875	1.750	3.750	1.312			

Can supply rod ends with different pitch or accuracy of thread.

For left-hand thread, suffix "L" is added to bearing numbers. eg.: SCML12T 3/4-16L