

## SPHS..

Ball: 440C stainless steel, heat treated HRC56min  
Precision ground polished

Body: SUS304 Stainless steel

Race: Brass

Sliding contact surfaces: Steel/Brass

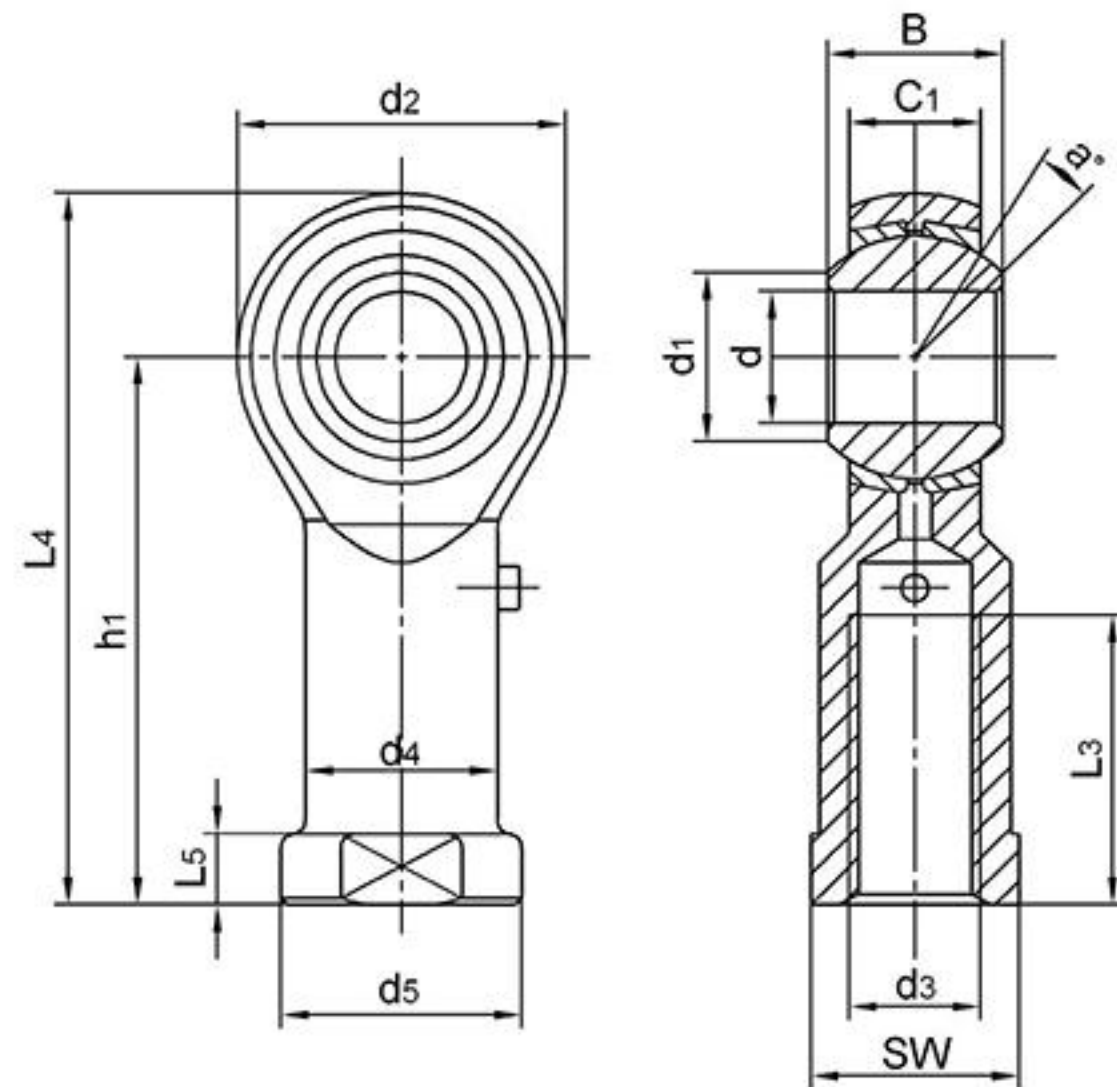

Bearing No.	Dimensions(mm)													Ball dia	a° mis. angle	Load ratings (KN)		weight ≈ Kg
	d <sub>H7</sub>	B	C <sub>1</sub>	d <sub>1</sub>	d <sub>2</sub>	d <sub>3-6H</sub>	h <sub>1</sub>	L <sub>3</sub>	(L <sub>4</sub> )	L <sub>5</sub>	d <sub>4</sub>	d <sub>5</sub>	SW			Dynamic	Static	
SPHS5	5	8	6	7.7	16	M5	27	11	35	4	9	11	9	11.11	13	2.5	6.6	0.016
SPHS6	6	9	6.75	8.9	18	M6	30	13	39	5	10	13	11	12.7	13	3.2	8.1	0.025
SPHS8	8	12	9	10.3	22	M8	36	16	47	5	12.5	16	14	15.87	14	5.4	12.6	0.043
SPHS10	10	14	10.5	12.9	26	M10	43	20	56	6.5	15	19	17	19.05	13	7.5	16.6	0.072
SPHS12	12	16	12	15.4	30	M12	50	23	65	6.5	17.5	22	19	22.22	13	10	22	0.107
SPHS14	14	19	13.5	16.8	34	M14	57	27	74	8	20	25	22	25.4	16	13	27.8	0.160
SPHS15	15	20	14	18.1	36	M14	61	30	79	8	21	26	22	26.98	16	14.5	29	0.186
SPHS16	16	21	15	19.3	38	M16	64	32	83	8	22	27	22	28.58	15	16	34.5	0.210
SPHS17	17	22	16	20.6	40	M16x1.5	67	34	87	10	24	31	27	30.16	14	18	36	0.259
SPHS18	18	23	16.5	21.8	42	M18x1.5	71	35	92	10	25	31	27	31.75	15	19.5	40.8	0.295
SPHS20	20	25	18	24.3	46	M20x1.5	77	39	100	10	27.5	34	30	34.92	14	23	46.5	0.380
SPHS22	22	28	20	25.8	50	M22x1.5	84	42	109	12	30	37	32	38.1	15	29	52.6	0.490
SPHS25	25	31	22	29.5	60	M24x2	94	48	124	12	33.5	42	36	42.86	15	40.5	74.1	0.750
SPHS28	28	35	24	32.29	66	M27x2	103	53	136	12	37	46	41	47.63	15	46.1	88.7	0.950
SPHS30	30	37	25	34.8	70	M30x2	110	56	145	15	40	50	41	50.8	17	54.3	94.0	1.130

Can supply rod ends with different pitch or accuracy of thread.

For left-hand thread, suffix "L" is added to bearing numbers. eg.: SPHS20L M20 x 1.5L-6H: