

## SCHS..

Ball: 440C Stainless steel, heat treated, HRC 56 min  
Precision ground, polished.

Body: 304 Stainless steel

Race: Brass or Stainless steel

PTFE composite bonded to I.D of race

Sliding contact surfaces: Steel/PTFE composite

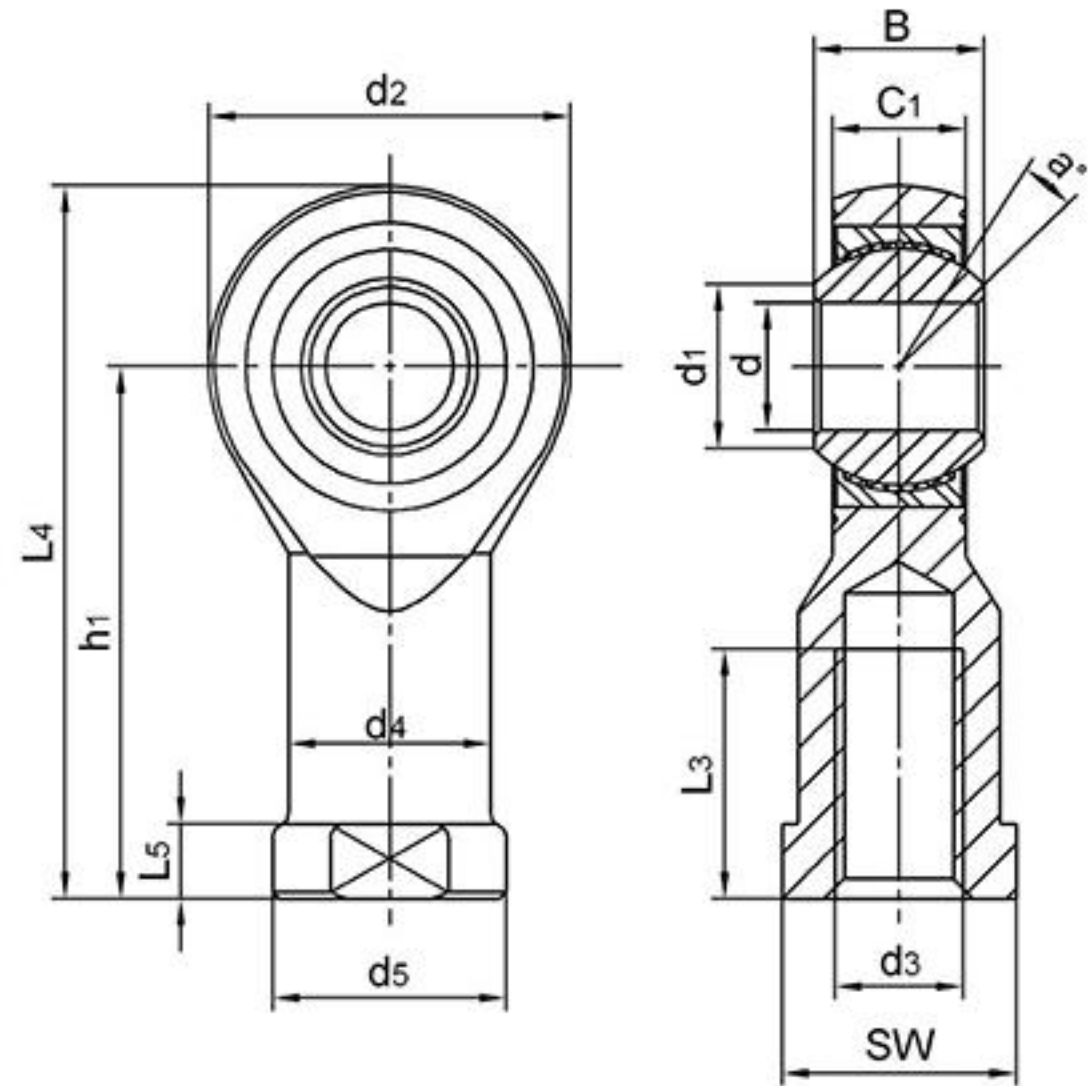

Bearing No.	Dimensions(mm)													Ball dia	a° mis. angle	Load ratings (KN)		weight ≈ Kg
	d <sub>H7</sub>	B	C <sub>1</sub>	d <sub>1</sub>	d <sub>2</sub>	d <sub>3-6H</sub>	h <sub>1</sub>	L <sub>3</sub>	L <sub>4</sub>	L <sub>5</sub>	d <sub>4</sub>	d <sub>5</sub>	SW			Dynamic	Static	
SCHS5	5	8	6	7.7	18	M5	27	10	36	4	9	11	9	11.11	13	3.2	8	0.016
SCHS6	6	9	6.75	8.9	20	M6	30	13	40	5	10	13	11	12.7	13	4.2	8.9	0.022
SCHS8	8	12	9	10.3	24	M8	36	16	48	5	12.5	16	13	15.87	14	7.1	14.1	0.047
SCHS10	10	14	10.5	12.9	28	M10	43	20	57	6.5	15	19	17	19.05	13	9.8	19.3	0.077
SCHS12	12	16	12	15.4	32	M12	50	22	66	6.5	17.5	22	19	22.22	13	13.2	23.5	0.100
SCHS14	14	19	13.5	16.8	36	M14	57	25	75	8	20	25	22	25.4	16	17	28	0.160
SCHS16	16	21	15	19.3	42	M16	64	28	85	8	22	27	22	28.58	15	21.4	32	0.220
SCHS18	18	23	16.5	21.8	46	M18x1.5	71	32	94	10	25	31	27	31.75	15	26	42.5	0.320
SCHS20	20	25	18	24.3	50	M20x1.5	77	33	102	10	27.5	34	30	34.92	14	31	47.5	0.420
SCHS22	22	28	20	25.8	54	M22x1.5	84	37	111	12	30	37	32	38.1	15	42.2	57	0.540
SCHS25	25	31	22	29.5	60	M24x2	94	42	124	12	33.5	42	36	42.86	15	52.7	68	0.730
SCHS28	28	35	24	32.29	66	M27x2	103	44	136	12	37	46	41	47.63	15	58.8	79	0.949
SCHS30	30	37	25	34.8	70	M30x2	110	51	145	15	40	50	41	50.8	17	70.7	88	1.100

Can supply rod ends with different pitch or accuracy of thread.

For left-hand thread, suffix "L" is added to bearing numbers. eg.: SCHS20L M20 x 1.5L-6H: