

# LDK<sup>®</sup> Stamped Steel Housed Units

## SAPF200/SAPFT200 Light duty, Eccentric locking, 3-Bolt flange housing

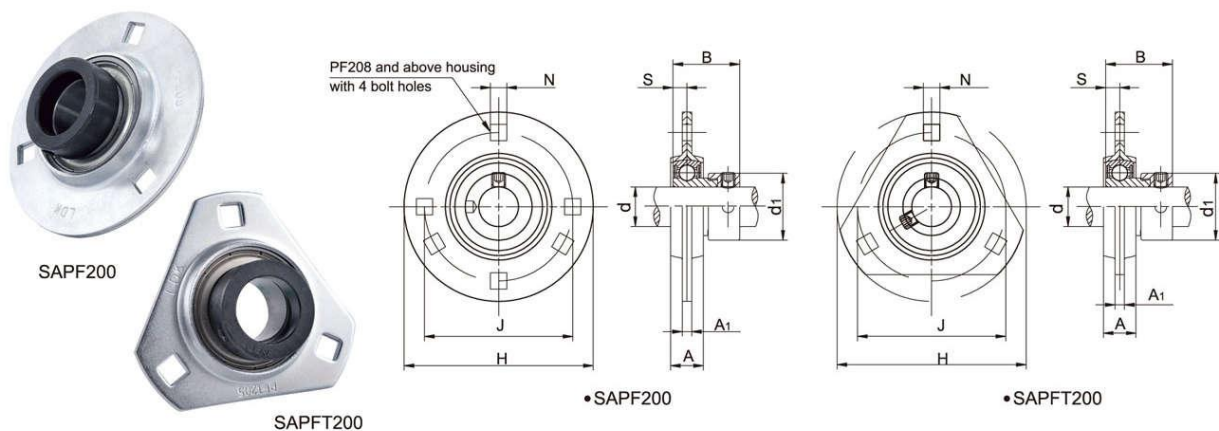

Unit No.	Shaft Dia d		Dimensions(mm)									Bolt Size		Weight (kg)
	(in)	(mm)	H	J	A	A <sub>1</sub>	d <sub>1</sub>	N	B <sub>1</sub>	S	(mm)	(in)		
201		12												
201-8	1/2													
202		15	81	63.5	14	4	28.6	7	28.6	6	M6	1/4	0.24	
202-10	5/8													
203		17												
203-11	11/16													
204		20	90	71	16	4	33.3	9	31	7	M8	5/16	0.35	
204-12	3/4													
205		25												
205-14	7/8		95	76	18	4	38.1	9	31.5	7.5	M8	5/16	0.42	
205-15	15/16													
205-16	1													
206		30												
206-18	1-1/8		113	90	18	5	44.5	11	35.7	8	M10	3/8	0.59	
206-19	1-3/16													
206-20	1-1/4													
SAPF SAPFT 207		35												
207-20	1-1/4													
207-21	1-5/16		122	100	20	5	55.6	11	38.9	8.5	M10	3/8	0.9	
207-22	1-3/8													
207-23	1-7/16													
208		40												
208-24	1-1/2		148	119	23	7	60.3	13.5	43.7	9	M12	1/2	1.11	
208-25	1-9/16													
209		45												
209-26	1-5/8		150	120.5	23	7	63.5	13.5	43.7	9.5	M12	1/2	1.48	
209-27	1-11/16													
209-28	1-3/4													
210		50												
210-30	1-7/8		157	127	25	8	63.5	13.5	43.7	10	M12	1/2	1.66	
210-31	1-15/16													
211		55												
211-32	2		168	138	26	8	63.5	13.5	48.4	10.5	M12	1/2	2.0	
211-34	2-1/8													
211-35	2-3/16													
212		60												
212-36	2-1/4		177	148	28	8	63.5	13.5	53.1	11	M12	1/2	2.1	
212-38	2-3/8													
212-39	2-7/16													

PF208~212 with 4 bolt holes.