

**PHS..**

Ball: Gcr15 Steel, heat treated, HRC58~64;  
Precision ground, polished

Body: Carbon steel, Zinc plated,chromate treated

Race: Brass

Sliding contact surfaces: Steel/Brass

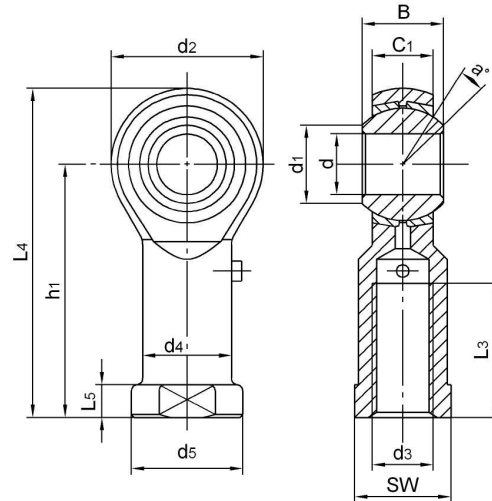

Bearing No.	Dimensions(mm)													Ball dia	a° mis. angle	Load ratings (KN)		weight ≈ Kg
	d <sub>H7</sub>	B	C <sub>1</sub>	d <sub>1</sub>	d <sub>2</sub>	d <sub>3-6H</sub>	h <sub>1</sub>	L <sub>3</sub>	(L <sub>4</sub> )	L <sub>5</sub>	d <sub>4</sub>	d <sub>5</sub>	SW			Dynamic	Static	
PHS3	3	6	4.5	5.1	12	M3	21	10	27	3	7	9	7	7.93	14	1.8	4.5	0.006
PHS4	4	7	5.25	6.5	14	M4	24	12	31	4	7.8	9.5	8	9.52	13	2.2	5.6	0.013
PHS5	5	8	6	7.7	16	M5	27	11	35	4	9	11	9	11.11	13	2.5	6.6	0.016
PHS6	6	9	6.75	8.9	18	M6	30	13	39	5	10	13	11	12.7	13	3.2	8.1	0.025
PHS8	8	12	9	10.3	22	M8	36	16	47	5	12.5	16	14	15.87	14	5.4	12.6	0.043
PHS10 PHS10F1	10	14	10.5	12.9	26	M10 M10x1.25	43	20	56	6.5	15	19	17	19.05	13	7.5	16.6	0.072
PHS12 PHS12/F2	12	16	12	15.4	30	M12 M12x1.25	50	23	65	6.5	17.5	22	19	22.22	13	10	22	0.107
PHS14 PHS14F1	14	19	13.5	16.8	34	M14 M14x1.5	57	27	74	8	20	25	22	25.4	16	13	27.8	0.160
PHS15	15	20	14	18.1	36	M14	61	30	79	8	21	26	22	26.98	16	14.5	29	0.186
PHS16 PHS16F1	16	21	15	19.3	38	M16 M16x1.5	64	32	83	8	22	27	22	28.58	15	16	34.5	0.210
PHS17	17	22	16	20.6	40	M16x1.5	67	34	87	10	24	31	27	30.16	14	18	36	0.259
PHS18	18	23	16.5	21.8	42	M18x1.5	71	35	92	10	25	31	27	31.75	15	19.5	40.8	0.295
PHS20	20	25	18	24.3	46	M20x1.5	77	39	100	10	27.5	34	30	34.92	14	23	46.5	0.380
PHS22	22	28	20	25.8	50	M22x1.5	84	42	109	12	30	37	32	38.1	15	29	52.6	0.490
PHS25	25	31	22	29.5	60	M24x2	94	48	124	12	33.5	42	36	42.86	15	40.5	74.1	0.750
PHS28	28	35	24	32.29	66	M27x2	103	53	136	12	37	46	41	47.63	15	46.1	88.7	0.950
PHS30	30	37	25	34.8	70	M30x2	110	56	145	15	40	50	41	50.8	17	54.3	94.0	1.130

Can supply rod ends with different pitch or accuracy of thread.

For left-hand thread, suffix"L" is added to bearing numbers. eg.: PHS20L M20 x 1.5L-6H:

**POS..**

Ball: Gcr15 Steel, heat treated, HRC58~64;  
Precision ground, polished

Body: Carbon steel, Zinc plated, chromate treated

Race: Brass

Sliding contact surfaces: Steel/Brass

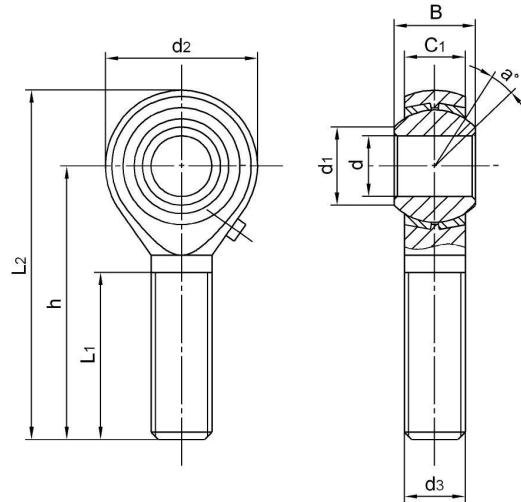

Bearing No.	Dimensions(mm)									Ball dia	a° mis. angle	Load ratings (KN)		weight ≈ Kg
	d <sub>H7</sub>	B	C <sub>1</sub>	d <sub>1</sub>	d <sub>2</sub>	d <sub>3</sub> -6g	h	L <sub>1</sub>	L <sub>2</sub>			Dynamic	Static	
POS3	3	6	4.5	5.1	12	M3	26	15	32	7.93	14	1.5	1.8	0.006
POS4	4	7	5.25	6.5	14	M4	30	19	37	9.52	13	2.0	2.9	0.011
POS5	5	8	6	7.7	16	M5	33	20	41	11.11	13	2.5	3.5	0.012
POS6	6	9	6.75	8.9	18	M6	36	22	45	12.7	13	3.2	4.8	0.019
POS8	8	12	9	10.3	22	M8	42	25	53	15.87	14	5.4	8.9	0.032
POS10	10	14	10.5	12.9	26	M10	48	29	61	19.05	13	7.5	12.5	0.054
POS10F1						M10x1.25								
POS12	12	16	12	15.4	30	M12	54	33	69	22.22	13	10	15.8	0.085
POS12/F2						M12x1.25								
POS14	14	19	13.5	16.8	34	M14	60	36	77	25.4	16	13	22.1	0.126
POS14F1						M14x1.5								
POS15	15	20	14	18.1	36	M14	63	38	81	26.98	16	14.5	23.6	0.186
POS16	16	21	15	19.3	38	M16	66	40	85	28.58	15	16	25.9	0.185
POS16F1						M16x1.5								
POS17	17	22	16	20.6	40	M16x1.5	69	42	89	30.16	14	18	28.4	0.259
POS18	18	23	16.5	21.8	42	M18x1.5	72	44	93	31.75	15	19.5	30.8	0.260
POS20	20	25	18	24.3	46	M20x1.5	78	47	101	34.92	14	23	36.2	0.340
POS22	22	28	20	25.8	50	M22x1.5	84	51	109	38.1	15	29	42.6	0.435
POS25	25	31	22	29.5	60	M24x2	94	57	124	42.86	15	40.5	74.1	0.650
POS28	28	35	24	32.29	66	M27x2	103	62	136	47.63	15	46.1	88.7	0.875
POS30	30	37	25	34.8	70	M30x2	110	66	145	50.8	17	54.3	94.0	1.070

Can supply rod ends with different pitch or accuracy of thread.

For left-hand thread, suffix "L" is added to bearing numbers. eg.: POS20L M20 x 1.5L-6g;

## CHS..

Ball: Gcr15 Steel, heat treated, HRC58~64;  
Precision ground, polished

Body: Carbon steel, Zinc plated, chromate treated

Race: Brass, PTFE composite bonded to I.D of race

Sliding contact surfaces: Steel/PTFE composite

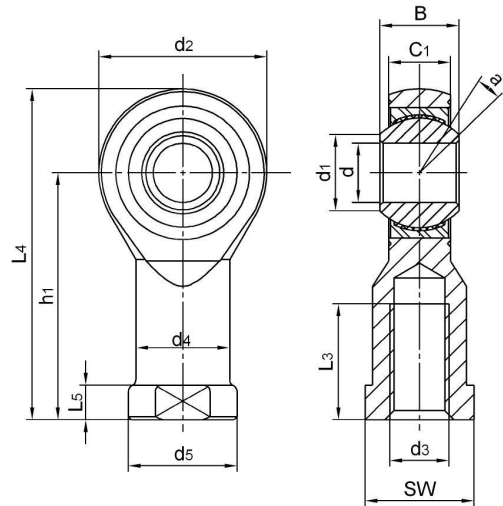

Bearing No.	Dimensions(mm)													Ball dia	a° mis. angle	Load ratings (KN)		weight ≈ Kg
	d <sub>HT</sub>	B	C1	d1	d2	d3-6H	h1	L3	(L4)	L5	d4	d5	SW			Dynamic	Static	
CHS3	3	6	4.5	5.1	14	M3	21	7	27	3	7	9	7	7.93	14	1.8	4.1	0.006
CHS4	4	7	5.25	6.5	16	M4	24	8	31	4	7.8	9.5	8	9.52	13	2.8	5.2	0.013
CHS5	5	8	6	7.7	18	M5	27	10	36	4	9	11	9	11.11	13	3.25	8	0.016
CHS6	6	9	6.75	8.9	20	M6	30	12	40	5	10	13	11	12.7	13	4.25	8.9	0.022
CHS8	8	12	9	10.3	24	M8	36	16	48	5	12.5	16	13	15.87	14	7.1	14.1	0.047
CHS10	10	14	10.5	12.9	28	M10	43	20	57	6.5	15	19	17	19.05	13	9.8	19.3	0.077
CHS12	12	16	12	15.4	32	M12	50	22	66	6.5	17.5	22	19	22.22	13	13.2	23.5	0.100
CHS14	14	19	13.5	16.8	36	M14	57	25	75	8	20	25	22	25.4	16	17	28	0.160
CHS16	16	21	15	19.3	42	M16	64	28	85	8	22	27	22	28.58	15	21.4	32	0.220
CHS18	18	23	16.5	21.8	46	M18x1.5	71	32	94	10	25	31	27	31.75	15	26	42.5	0.320
CHS20	20	25	18	24.3	50	M20x1.5	77	33	102	10	27.5	34	30	34.92	14	31	47.5	0.420
CHS22	22	28	20	25.8	54	M22x1.5	84	37	111	12	30	37	32	38.1	15	42.2	57	0.540
CHS25	25	31	22	29.5	60	M24x2	94	42	124	12	33.5	42	36	42.86	15	52.7	68	0.730
CHS28	28	35	24	32.29	66	M27x2	103	44	136	12	37	46	41	47.63	15	58.8	79	0.949
CHS30	30	37	25	34.8	70	M30x2	110	51	145	15	40	50	41	50.8	17	70.7	88	1.100

Can supply rod ends with different pitch or accuracy of thread.

For left-hand thread, suffix "L" is added to bearing numbers. eg.: CHS20L M20 x 1.5L-6H:



**COS..**

Ball: Gcr15 Steel, heat treated, HRC58~64;  
Precision ground, polished

Body: Carbon steel, Zinc plated,chromate treated

Race: Brass, PTFE composite bonded to I.D of race

Sliding contact surfaces: Steel/PTFE composite

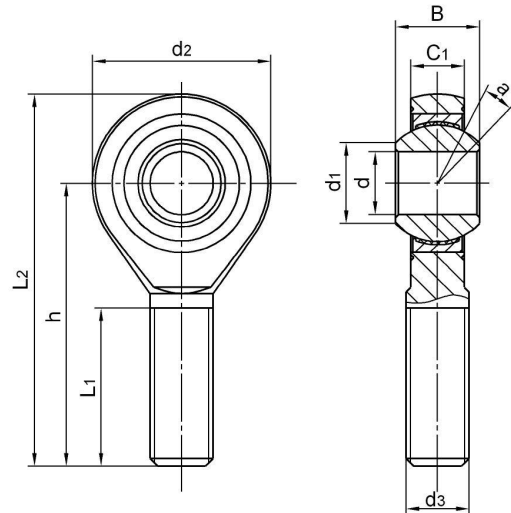

Bearing No.	Dimensions(mm)									Ball dia	a° mis. angle	Load ratings (KN)		weight ≈ Kg
	d <sub>H7</sub>	B	C <sub>1</sub>	d <sub>1</sub>	d <sub>2</sub>	d <sub>3-6g</sub>	h	L <sub>1</sub>	L <sub>2</sub>			Dynamic	Static	
COS3	3	6	4.5	5.1	14	M3	26	15	33	7.93	14	1.5	1.8	0.006
COS4	4	7	5.25	6.5	16	M4	30	19	38	9.52	13	2.0	2.9	0.011
COS5	5	8	6	7.7	18	M5	33	19	42	11.11	13	3.25	4.3	0.013
COS6	6	9	6.75	8.9	20	M6	36	21	46	12.7	13	4.25	6	0.020
COS8	8	12	9	10.3	24	M8	42	25	54	15.87	14	7.1	11	0.038
COS10	10	14	10.5	12.9	28	M10	48	28	63	19.05	13	9.8	17.4	0.055
COS12	12	16	12	15.4	32	M12	54	32	71	22.22	13	13.2	23.5	0.085
COS14	14	19	13.5	16.8	36	M14	60	36	79	25.4	16	17	28	0.140
COS16	16	21	15	19.3	42	M16	66	37	87	28.58	15	21.4	32	0.210
COS18	18	23	16.5	21.8	46	M18x1.5	72	41	95	31.75	15	26	42.5	0.280
COS20	20	25	18	24.3	50	M20x1.5	78	45	103	34.92	14	31	47.5	0.380
COS22	22	28	20	25.8	54	M22x1.5	84	48	112	38.1	15	42.2	57	0.480
COS25	25	31	22	29.5	60	M24x2	94	55	124	42.86	15	52.7	68	0.640
COS28	28	35	24	32.29	66	M27x2	103	62	136	47.63	15	58.8	79	0.949
COS30	30	37	25	34.8	70	M30x2	110	66	145	50.8	17	70.7	88	1.100

Can supply rod ends with different pitch or accuracy of thread.

For left-hand thread, suffix"L" is added to bearing numbers. eg.: COS20L M20 x 1.5L-6g;

## PHS..EC

Ball: Gcr15 Steel, heat treated, HRC58~64;  
Precision ground, polished

Body: Carbon steel, Zinc plated, chromate treated

Race: PTFE composite

Sliding contact surfaces: Steel/PTFE composite

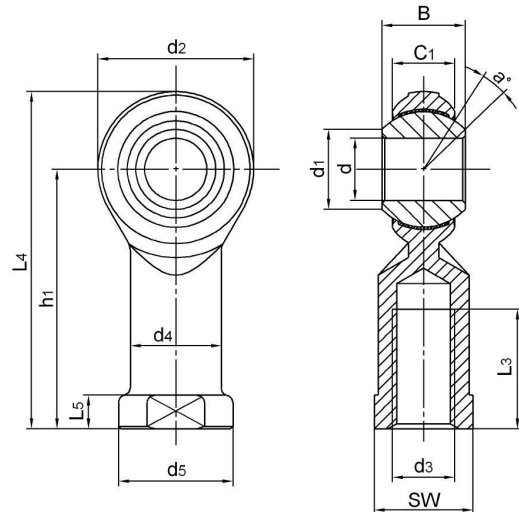

Bearing No.	Dimensions(mm)													Ball dia	a° mis. angle	Load ratings (KN)		weight ≈ Kg
	d <sub>H7</sub>	B	C <sub>1 max</sub>	d <sub>1</sub>	d <sub>2</sub>	d <sub>3-6H</sub>	h <sub>1</sub>	L <sub>3</sub>	L <sub>4</sub>	L <sub>5</sub>	d <sub>4</sub>	d <sub>5</sub>	SW			Dynamic	Static	
PHS5EC	5	8	6	7.7	16	M5	27	11	35	4	9	11	9	11.11	13	3.3	6.2	0.016
PHS6EC	6	9	6.75	8.9	18	M6	30	13	39	5	10	13	11	12.7	13	4.7	7.8	0.025
PHS8EC	8	12	9	10.3	22	M8	36	16	47	5	12.5	16	14	15.87	14	7.7	13.2	0.043
PHS10EC	10	14	10.5	12.9	26	M10	43	20	56	6.5	15	19	17	19.05	13	10.4	17.3	0.072
PHS12EC	12	16	12	15.4	30	M12	50	23	65	6.5	17.5	22	19	22.22	13	13.5	22.7	0.107
PHS14EC	14	19	13.5	16.8	34	M14	57	27	74	8	20	25	22	25.4	16	17.2	28.2	0.160
PHS16EC	16	21	15	19.3	38	M16	64	32	83	8	22	27	22	28.58	15	21	35.1	0.210
PHS18EC	18	23	16.5	21.8	42	M18x1.5	71	35	92	10	25	31	27	31.75	15	25	43.2	0.295
PHS20EC	20	25	18	24.3	46	M20x1.5	77	39	100	10	27.5	34	30	34.92	14	29.8	50.3	0.380
PHS22EC	22	28	20	25.8	50	M22x1.5	84	42	109	12	30	37	32	38.1	15	36.2	63.9	0.490

Can supply rod ends with different pitch or accuracy of thread.

For left-hand thread, suffix "L" is added to bearing numbers. eg.: PHS20ECL M20 x 1.5L-6H:



**POS..EC**

Ball: Gcr15 Steel, heat treated, HRC58~64;  
Precision ground, polished

Body: Carbon steel, Zinc plated,chromate treated

Race: PTFE composite

Sliding contact surfaces: Steel/PTFE composite

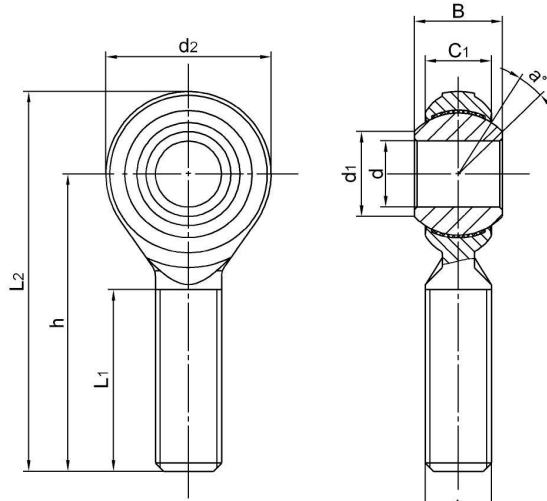

Bearing No.	Dimensions(mm)									Ball dia	a° mis. angle	Load ratings (KN)		weight ≈ Kg
	d <sub>H7</sub>	B	C <sub>1 MAX</sub>	d <sub>1</sub>	d <sub>2</sub>	d <sub>3-6g</sub>	h	L <sub>1</sub>	L <sub>2</sub>			Dynamic	Static	
POS5EC	5	8	6	7.7	16	M5	33	20	41	11.11	13	3.3	4.8	0.012
POS6EC	6	9	6.75	8.9	18	M6	36	22	45	12.7	13	4.7	6.8	0.019
POS8EC	8	12	9	10.3	22	M8	42	25	53	15.87	14	7.7	12.3	0.032
POS10EC	10	14	10.5	12.9	26	M10	48	29	61	19.05	13	10.4	17.3	0.054
POS12EC	12	16	12	15.4	30	M12	54	33	69	22.22	13	13.5	22.7	0.085
POS14EC	14	19	13.5	16.8	34	M14	60	36	77	25.4	16	17.2	28.2	0.126
POS16EC	16	21	15	19.3	38	M16	66	40	85	28.58	15	21	35.1	0.185
POS18EC	18	23	16.5	21.8	42	M18x1.5	72	44	93	31.75	15	25	43.2	0.260
POS20EC	20	25	18	24.3	46	M20x1.5	78	47	101	34.92	14	29.8	50.3	0.340
POS22EC	22	28	20	25.8	50	M22x1.5	84	51	109	38.1	15	36.2	63.9	0.435

Can supply rod ends with different pitch or accuracy of thread.

For left-hand thread, suffix"L" is added to bearing numbers. eg.: POS20ECL M20 x 1.5L-6H:

## PHS..HD

Ball: Gcr15 Steel, heat treated, HRC58~64;  
Precision ground, polished

Body: Carbon steel, Zinc plated,chromate treated

Race: Brass

Sliding contact surfaces: Steel/Brass

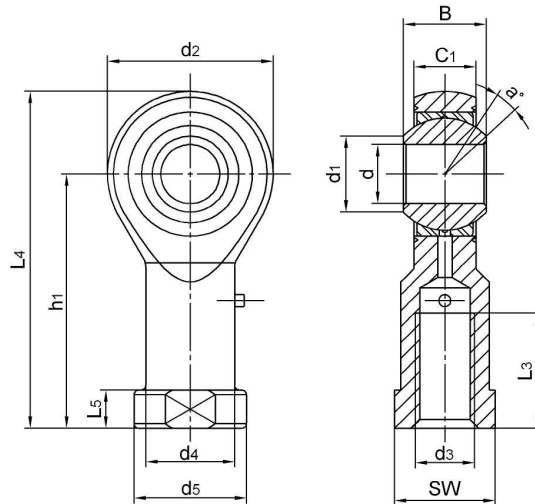

Bearing No.	Dimensions(mm)													Ball dia	a° mis. angle	Load ratings (KN)		weight ≈ Kg
	d <sub>H7</sub>	B	C1	d1	d2	d3-6H	h1	L3	(L4)	L5	d4	d5	SW			Dynamic	Static	
PHS5HD	5	8	6	7.7	18	M5	27	10	36	4	9	11	9	11.11	13	3.2	8	0.016
PHS6HD	6	9	6.75	8.9	20	M6	30	12	40	5	10	13	11	12.7	13	4.2	8.9	0.022
PHS8HD	8	12	9	10.3	24	M8	36	16	48	5	12.5	16	13	15.87	14	7.1	14.1	0.047
PHS10HD	10	14	10.5	12.9	28	M10	43	20	57	6.5	15	19	17	19.05	13	9.8	19.3	0.077
PHS12HD	12	16	12	15.4	32	M12	50	22	66	6.5	17.5	22	19	22.22	13	13.2	23.5	0.100
PHS14HD	14	19	13.5	16.8	36	M14	57	25	75	8	20	25	22	25.4	16	17	28	0.160
PHS16HD	16	21	15	19.3	42	M16	64	28	85	8	22	27	22	28.58	15	21.4	32	0.220
PHS18HD	18	23	16.5	21.8	46	M18x1.5	71	32	94	10	25	31	27	31.75	15	26	42.5	0.320
PHS20HD	20	25	18	24.3	50	M20x1.5	77	33	102	10	27.5	34	30	34.92	14	31	47.5	0.420
PHS22HD	22	28	20	25.8	54	M22x1.5	84	37	111	12	30	37	32	38.1	15	42.2	57	0.540
PHS25HD	25	31	22	29.5	60	M24x2	94	42	124	12	33.5	42	36	42.86	15	52.7	68	0.730
PHS28HD	28	35	24	32.29	66	M27x2	103	44	136	12	37	46	41	47.63	15	58.8	79	0.949
PHS30HD	30	37	25	34.8	70	M30x2	110	51	145	15	40	50	41	50.8	17	70.7	88	1.100

Can supply rod ends with different pitch or accuracy of thread.

For left-hand thread, suffix"L" is added to bearing numbers. eg.: PHS20HDL M20 x 1.5L-6H:



**POS..HD**

Ball: Gcr15 Steel, heat treated, HRC58~64;  
Precision ground, polished

Body: Carbon steel, Zinc plated,chromate treated

Race: Brass

Sliding contact surfaces: Steel/Brass

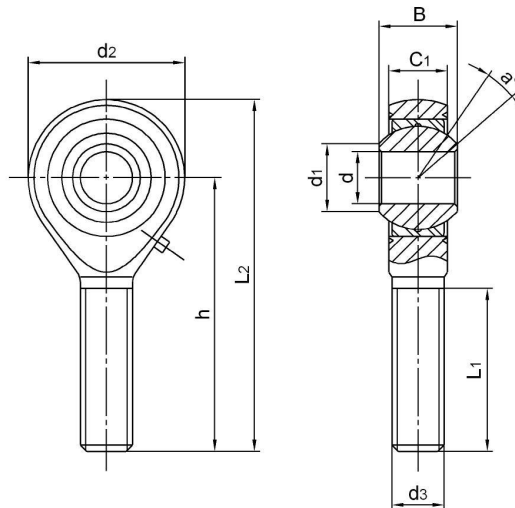

Bearing No.	Dimensions(mm)									Ball dia	a° mis. angle	Load ratings (KN)		weight ≈ Kg
	d <sub>H7</sub>	B	C1	d1	d2	d3-6g	h	L1	L2			Dynamic	Static	
POS5HD	5	8	6	7.7	18	M5	33	19	42	11.11	13	3.2	4.3	0.013
POS6HD	6	9	6.75	8.9	20	M6	36	21	46	12.7	13	4.2	6	0.020
POS8HD	8	12	9	10.3	24	M8	42	25	54	15.87	14	7.1	11	0.038
POS10HD	10	14	10.5	12.9	28	M10	48	28	63	19.05	13	9.8	17.4	0.055
POS12HD	12	16	12	15.4	32	M12	54	32	71	22.22	13	13.2	23.5	0.085
POS14HD	14	19	13.5	16.8	36	M14	60	36	79	25.4	16	17	28	0.140
POS16HD	16	21	15	19.3	42	M16	66	37	87	28.58	15	21.4	32	0.210
POS18HD	18	23	16.5	21.8	46	M18x1.5	72	41	95	31.75	15	26	42.5	0.280
POS20HD	20	25	18	24.3	50	M20x1.5	78	45	103	34.925	14	31	47.5	0.380
POS22HD	22	28	20	25.8	54	M22x1.5	84	48	112	38.1	15	42.2	57	0.480
POS25HD	25	31	22	29.5	60	M24x2	94	55	124	42.86	15	52.7	68	0.640
POS28HD	28	35	24	32.29	66	M27x2	103	62	136	47.63	15	58.8	79	0.949
POS30HD	30	37	25	34.8	70	M30x2	110	66	145	50.8	17	70.7	88	1.100

Can supply rod ends with different pitch or accuracy of thread.

For left-hand thread, suffix"L" is added to bearing numbers. eg.: POS20HDL M20 x 1.5L-6g:



**SPHS..**

- Ball: 440C stainless steel, heat treated HRC56min  
Precision ground polished
- Body: SUS304 Stainless steel
- Race: Brass
- Sliding contact surfaces: Steel/Brass

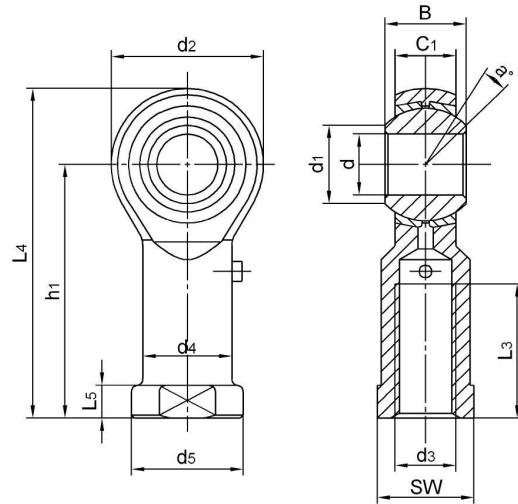

Bearing No.	Dimensions(mm)													Ball dia	a° mis. angle	Load ratings (KN)		weight ≈ Kg
	d <sub>H7</sub>	B	C <sub>1</sub>	d <sub>1</sub>	d <sub>2</sub>	d <sub>3</sub> -6H	h <sub>1</sub>	L <sub>3</sub>	(L <sub>4</sub> )	L <sub>5</sub>	d <sub>4</sub>	d <sub>5</sub>	SW			Dynamic	Static	
SPHS5	5	8	6	7.7	16	M5	27	11	35	4	9	11	9	11.11	13	2.5	6.6	0.016
SPHS6	6	9	6.75	8.9	18	M6	30	13	39	5	10	13	11	12.7	13	3.2	8.1	0.025
SPHS8	8	12	9	10.3	22	M8	36	16	47	5	12.5	16	14	15.87	14	5.4	12.6	0.043
SPHS10	10	14	10.5	12.9	26	M10	43	20	56	6.5	15	19	17	19.05	13	7.5	16.6	0.072
SPHS12	12	16	12	15.4	30	M12	50	23	65	6.5	17.5	22	19	22.22	13	10	22	0.107
SPHS14	14	19	13.5	16.8	34	M14	57	27	74	8	20	25	22	25.4	16	13	27.8	0.160
SPHS15	15	20	14	18.1	36	M14	61	30	79	8	21	26	22	26.98	16	14.5	29	0.186
SPHS16	16	21	15	19.3	38	M16	64	32	83	8	22	27	22	28.58	15	16	34.5	0.210
SPHS17	17	22	16	20.6	40	M16x1.5	67	34	87	10	24	31	27	30.16	14	18	36	0.259
SPHS18	18	23	16.5	21.8	42	M18x1.5	71	35	92	10	25	31	27	31.75	15	19.5	40.8	0.295
SPHS20	20	25	18	24.3	46	M20x1.5	77	39	100	10	27.5	34	30	34.92	14	23	46.5	0.380
SPHS22	22	28	20	25.8	50	M22x1.5	84	42	109	12	30	37	32	38.1	15	29	52.6	0.490
SPHS25	25	31	22	29.5	60	M24x2	94	48	124	12	33.5	42	36	42.86	15	40.5	74.1	0.750
SPHS28	28	35	24	32.29	66	M27x2	103	53	136	12	37	46	41	47.63	15	46.1	88.7	0.950
SPHS30	30	37	25	34.8	70	M30x2	110	56	145	15	40	50	41	50.8	17	54.3	94.0	1.130

Can supply rod ends with different pitch or accuracy of thread.

For left-hand thread, suffix"L" is added to bearing numbers. eg.: SPHS20L M20 x 1.5L-6H:

**SPOS..**

Ball: 440C stainless steel, heat treated HRC56min  
Precision ground polished

Body: SUS304 Stainless steel

Race: Brass

Sliding contact surfaces: Steel/Brass

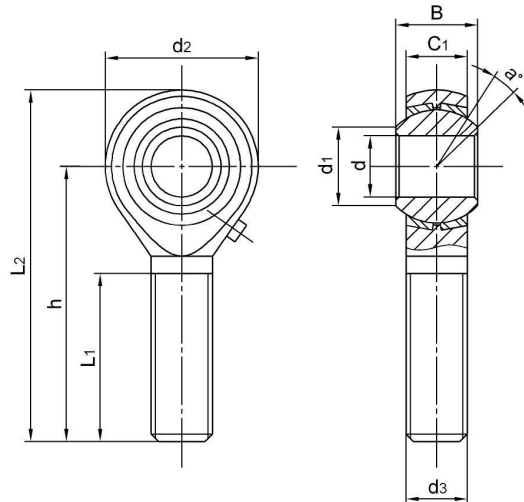

Bearing No.	Dimensions(mm)									Ball dia	a° mis. angle	Load ratings (KN)		weight ≈ Kg
	d <sub>H7</sub>	B	C <sub>1</sub>	d <sub>1</sub>	d <sub>2</sub>	d <sub>3-6g</sub>	h	L <sub>1</sub>	L <sub>2</sub>			Dynamic	Static	
SPOS5	5	8	6	7.7	16	M5	33	20	41	11.11	13	2.5	3.5	0.012
SPOS6	6	9	6.75	8.9	18	M6	36	22	45	12.7	13	3.2	4.8	0.019
SPOS8	8	12	9	10.3	22	M8	42	25	53	15.87	14	5.4	8.9	0.032
SPOS10	10	14	10.5	12.9	26	M10	48	29	61	19.05	13	7.5	12.5	0.054
SPOS12	12	16	12	15.4	30	M12	54	33	69	22.22	13	10	15.8	0.085
SPOS14	14	19	13.5	16.8	34	M14	60	36	77	25.4	16	13	22.1	0.126
SPOS15	15	20	14	18.1	36	M14	63	38	81	26.98	16	14.5	23.6	0.186
SPOS16	16	21	15	19.3	38	M16	66	40	85	28.58	15	16	25.9	0.185
SPOS17	17	22	16	20.6	40	M16x1.5	69	42	89	30.16	14	18	28.4	0.259
SPOS18	18	23	16.5	21.8	42	M18x1.5	72	44	93	31.75	15	19.5	30.8	0.260
SPOS20	20	25	18	24.3	46	M20x1.5	78	47	101	34.925	14	23	36.2	0.340
SPOS22	22	28	20	25.8	50	M22x1.5	84	51	109	38.1	15	29	42.6	0.435
SPOS25	25	31	22	29.5	60	M24x2	94	57	124	42.86	15	40.5	74.4	0.650
SPOS28	28	35	24	32.29	66	M27x2	103	62	136	47.63	15	46.1	88.7	0.875
SPOS30	30	37	25	34.8	70	M30x2	110	66	145	50.8	17	54.3	94.0	1.070

Can supply rod ends with different pitch or accuracy of thread.

For left-hand thread, suffix"L" is added to bearing numbers. eg.: SPOS20L M20 x 1.5L-6g:

## SCHS..

Ball: 440C Stainless steel, heat treated, HRC 56 min  
Precision ground, polished.

Body: 304 Stainless steel

Race: Brass or Stainless steel

PTFE composite bonded to I.D of race

Sliding contact surfaces: Steel/PTFE composite

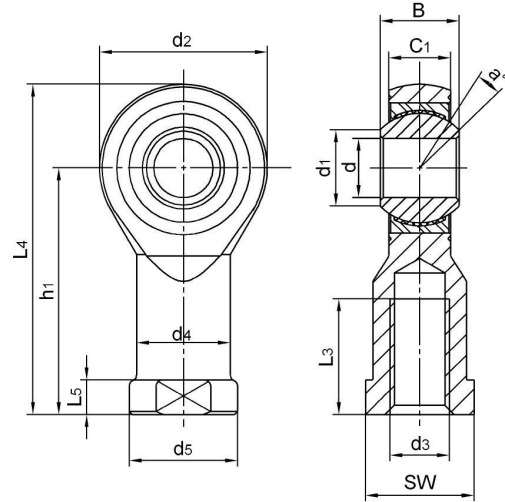

Bearing No.	Dimensions(mm)													Ball dia	a° mis. angle	Load ratings (KN)		weight ≈ Kg
	d <sub>H7</sub>	B	C <sub>1</sub>	d <sub>1</sub>	d <sub>2</sub>	d <sub>3-6H</sub>	h <sub>1</sub>	L <sub>3</sub>	L <sub>4</sub>	L <sub>5</sub>	d <sub>4</sub>	d <sub>5</sub>	SW			Dynamic	Static	
SCHS5	5	8	6	7.7	18	M5	27	10	36	4	9	11	9	11.11	13	3.2	8	0.016
SCHS6	6	9	6.75	8.9	20	M6	30	13	40	5	10	13	11	12.7	13	4.2	8.9	0.022
SCHS8	8	12	9	10.3	24	M8	36	16	48	5	12.5	16	13	15.87	14	7.1	14.1	0.047
SCHS10	10	14	10.5	12.9	28	M10	43	20	57	6.5	15	19	17	19.05	13	9.8	19.3	0.077
SCHS12	12	16	12	15.4	32	M12	50	22	66	6.5	17.5	22	19	22.22	13	13.2	23.5	0.100
SCHS14	14	19	13.5	16.8	36	M14	57	25	75	8	20	25	22	25.4	16	17	28	0.160
SCHS16	16	21	15	19.3	42	M16	64	28	85	8	22	27	22	28.58	15	21.4	32	0.220
SCHS18	18	23	16.5	21.8	46	M18x1.5	71	32	94	10	25	31	27	31.75	15	26	42.5	0.320
SCHS20	20	25	18	24.3	50	M20x1.5	77	33	102	10	27.5	34	30	34.92	14	31	47.5	0.420
SCHS22	22	28	20	25.8	54	M22x1.5	84	37	111	12	30	37	32	38.1	15	42.2	57	0.540
SCHS25	25	31	22	29.5	60	M24x2	94	42	124	12	33.5	42	36	42.86	15	52.7	68	0.730
SCHS28	28	35	24	32.29	66	M27x2	103	44	136	12	37	46	41	47.63	15	58.8	79	0.949
SCHS30	30	37	25	34.8	70	M30x2	110	51	145	15	40	50	41	50.8	17	70.7	88	1.100

Can supply rod ends with different pitch or accuracy of thread.

For left-hand thread, suffix "L" is added to bearing numbers. eg.: SCHS20L M20 x 1.5L-6H:

**SCOS..**

Ball: 440C Stainless steel, heat treated, HRC 56min

Precision ground polished

Body: 304 Stainless steel

Race: Brass or Stainless steel,

PTFE composite bonded to I.D of race

Sliding contact surfaces: Steel/PTFE composite.

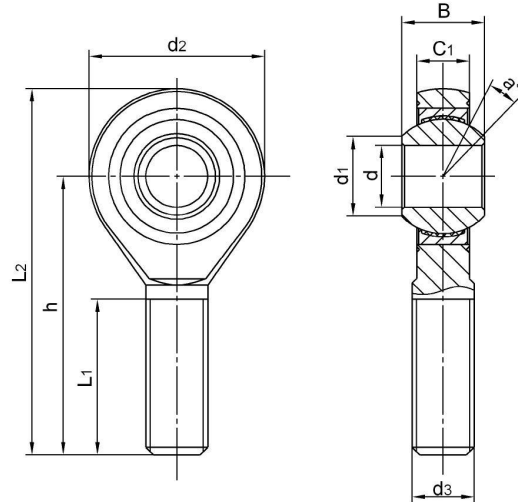

Bearing No.	Dimensions(mm)									Ball dia	a° mis. angle	Load ratings (KN)		weight ≈ Kg
	d <sub>H7</sub>	B	C <sub>1</sub>	d <sub>1</sub>	d <sub>2</sub>	d <sub>3-6g</sub>	h	L <sub>1</sub>	L <sub>2</sub>			Dynamic	Static	
SCOS5	5	8	6	7.7	18	M5	33	19	42	11.11	13	3.2	4.3	0.013
SCOS6	6	9	6.75	8.9	20	M6	36	21	46	12.7	13	4.2	6	0.020
SCOS8	8	12	9	10.3	24	M8	42	25	54	15.87	14	7.1	11	0.038
SCOS10	10	14	10.5	12.9	28	M10	48	28	63	19.05	13	9.8	17.4	0.055
SCOS12	12	16	12	15.4	32	M12	54	32	71	22.22	13	13.2	23.5	0.085
SCOS14	14	19	13.5	16.8	36	M14	60	36	79	25.4	16	17	28	0.140
SCOS16	16	21	15	19.3	42	M16	66	37	87	28.58	15	21.4	32	0.210
SCOS18	18	23	16.5	21.8	46	M18x1.5	72	41	95	31.75	15	26	42.5	0.280
SCOS20	20	25	18	24.3	50	M20x1.5	78	45	103	34.92	14	31	47.5	0.380
SCOS22	22	28	20	25.8	54	M22x1.5	84	48	112	38.1	15	42.2	57	0.480
SCOS25	25	31	22	29.5	60	M24x2	94	55	124	42.86	15	52.7	68	0.640
SCOS28	28	35	25	32.29	66	M27x2	103	62	136	47.63	15	58.8	79	0.949
SCOS30	30	37	25	34.8	70	M30x2	110	66	145	50.8	17	70.7	88	1.100

Can supply rod ends with different pitch or accuracy of thread.

For left-hand thread, suffix "L" is added to bearing numbers. eg.: SCOS20L M20 x 1.5L-6g:

## SPHS..EC

Ball: 440C Stainless steel, heat treated, HRC 56min  
Precision ground, polished

Body: 304 Stainless steel

Race: PTFE composite

Sliding contact surfaces: Steel/PTFE composite

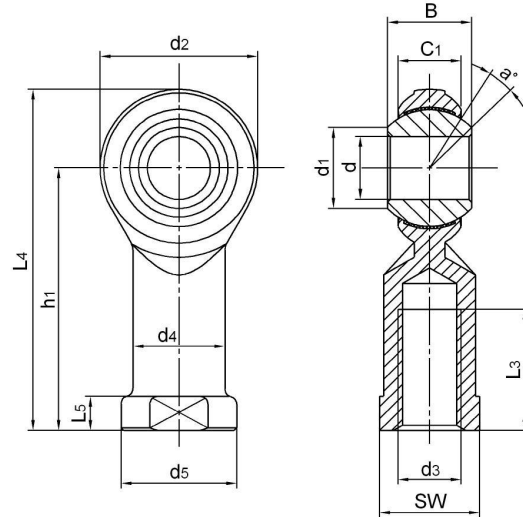

Bearing No.	Dimensions(mm)													Ball dia	a° mis. angle	Load ratings (KN)		weight ≈ Kg
	d <sub>H7</sub>	B	C <sub>1 max</sub>	d <sub>1</sub>	d <sub>2</sub>	d <sub>3-6H</sub>	h <sub>1</sub>	L <sub>3</sub>	L <sub>4</sub>	L <sub>5</sub>	d <sub>4</sub>	d <sub>5</sub>	SW			Dynamic	Static	
SPHS5EC	5	8	6	7.7	16	M5	27	11	35	4	9	11	9	11.11	13	3.3	6.2	0.016
SPHS6EC	6	9	6.75	8.9	18	M6	30	13	39	5	10	13	11	12.7	13	4.7	7.8	0.025
SPHS8EC	8	12	9	10.3	22	M8	36	16	47	5	12.5	16	14	15.87	14	7.7	13.2	0.043
SPHS10EC	10	14	10.5	12.9	26	M10	43	20	56	6.5	15	19	17	19.05	13	10.4	17.3	0.072
SPHS12EC	12	16	12	15.4	30	M12	50	23	65	6.5	17.5	22	19	22.22	13	13.5	22.7	0.107
SPHS14EC	14	19	13.5	16.8	34	M14	57	27	74	8	20	25	22	25.4	16	17.2	28.2	0.160
SPHS16EC	16	21	15	19.3	38	M16	64	32	83	8	22	27	22	28.58	15	21	35.1	0.210
SPHS18EC	18	23	16.5	21.8	42	M18x1.5	71	35	92	10	25	31	27	31.75	15	25	43.2	0.295
SPHS20EC	20	25	18	24.3	46	M20x1.5	77	39	100	10	27.5	34	30	34.92	14	29.8	50.3	0.380

Can supply rod ends with different pitch or accuracy of thread.

For left-hand thread, suffix "L" is added to bearing numbers. eg.: SPHS20ECL M20 x 1.5L-6H:



**SPOS..EC**

Ball: 440C Stainless steel, heat treated, HRC 56min  
Precision ground polished

Body: 304 Stainless steel.

Race: PTFE composite

Sliding contact surfaces: Steel/PTFE composite.

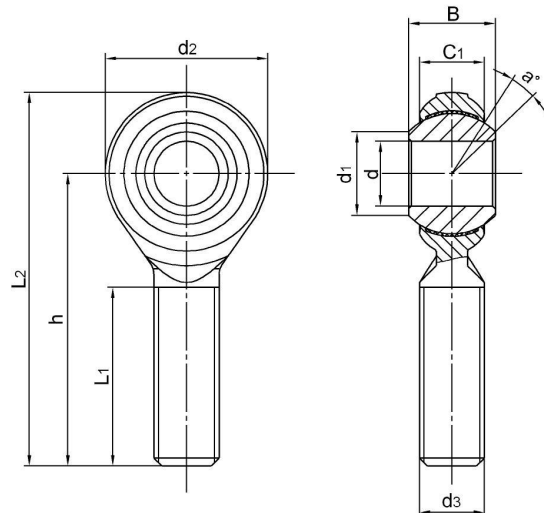

Bearing No.	Dimensions(mm)									Ball dia	a° mis. angle	Load ratings (KN)		weight ≈ Kg
	d <sub>H7</sub>	B	C <sub>1 max</sub>	d <sub>1</sub>	d <sub>2</sub>	d <sub>3-6g</sub>	h	L <sub>1</sub>	L <sub>2</sub>			Dynamic	Static	
SPOS5EC	5	8	6	7.7	16	M5	33	20	41	11.11	13	3.3	4.8	0.012
SPOS6EC	6	9	6.75	8.9	18	M6	36	22	45	12.7	13	4.7	6.8	0.019
SPOS8EC	8	12	9	10.3	22	M8	42	25	53	15.87	14	7.7	12.3	0.032
SPOS10EC	10	14	10.5	12.9	26	M10	48	29	61	19.05	13	10.4	17.3	0.054
SPOS12EC	12	16	12	15.4	30	M12	54	33	69	22.22	13	13.5	22.7	0.085
SPOS14EC	14	19	13.5	16.8	34	M14	60	36	77	25.4	16	17.2	28.2	0.126
SPOS16EC	16	21	15	19.3	38	M16	66	40	85	28.58	15	21	35.1	0.185
SPOS18EC	18	23	16.5	21.8	42	M18x1.5	72	44	93	31.75	15	25	43.2	0.260
SPOS20EC	20	25	18	24.3	46	M20x1.5	78	47	101	34.92	14	29.8	50.3	0.340

Can supply rod ends with different pitch or accuracy of thread.

For left-hand thread, suffix "L" is added to bearing numbers. eg.: SPOS20ECL M20 x 1.5L-6g:

## NPHS..

Ball: Gcr15 steel, heat treated, HRC 58 ~64;  
Precision ground, polished.

Body: Carbon steel, zinc plated, chromate treated

Race: Nylon polymer

Sliding contact surfaces: Steel/Nylon

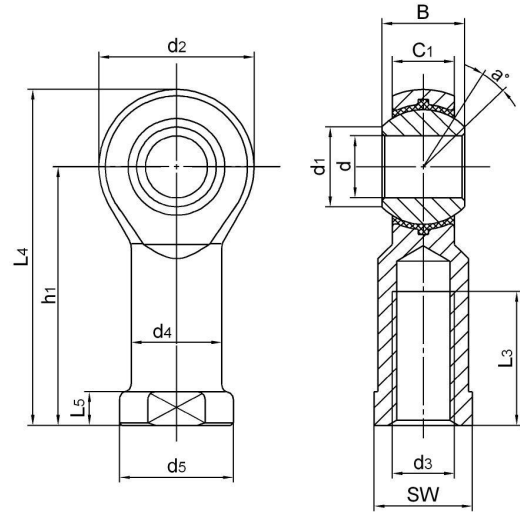

Bearing No.	Dimensions(mm)													Ball dia	a° mis. angle	Load ratings (KN)		weight ≈ Kg
	d <sub>H7</sub>	B	C <sub>1</sub>	d <sub>1</sub>	d <sub>2</sub>	d <sub>3-6H</sub>	h <sub>1</sub>	L <sub>3</sub>	L <sub>4</sub>	L <sub>5</sub>	d <sub>4</sub>	d <sub>5</sub>	SW			Dynamic	Static	
NPHS5	5	8	6	7.7	16	M5	27	13	35	4	9	11	9	11.11	13	2.5	6.6	0.016
NPHS6	6	9	6.75	8.9	18	M6	30	13	39	5	10	13	11	12.7	13	3.2	8.1	0.025
NPHS8	8	12	9	10.3	22	M8	36	17	47	5	12.5	16	14	15.87	14	5.4	12.6	0.043
NPHS10	10	14	10.5	12.9	26	M10	43	21	56	6.5	15	19	17	19.05	13	7.5	16.6	0.072
NPHS12	12	16	12	15.4	30	M12	50	24	65	6.5	17.5	22	19	22.22	13	10	22	0.107
NPHS14	14	19	13.5	16.8	34	M14	57	27	74	8	20	25	22	25.4	16	13	27.8	0.160
NPHS16	16	21	15	19.3	38	M16	64	33	83	8	22	27	22	28.58	15	16	34.5	0.210
NPHS18	18	23	16.5	21.8	42	M18x1.5	71	36	92	10	25	31	27	31.75	15	19.5	40.8	0.295
NPHS20	20	25	18	24.3	46	M20x1.5	77	40	100	10	27.5	34	30	34.92	14	23	46.5	0.380
NPHS22	22	28	20	25.8	50	M22x1.5	84	43	109	12	30	37	32	38.1	15	29	52.6	0.490
NPHS25	25	31	22	29.5	60	M24x2	94	48	124	12	33.5	42	36	42.86	15	40.5	74.1	0.750
NPHS28	28	35	24	32.29	66	M27x2	103	53	136	12	37	46	41	47.63	15	46.1	88.7	0.950
NPHS30	30	37	25	34.8	70	M30x2	110	56	145	15	40	50	41	50.8	17	54.3	94	1.130

Can supply rod ends with different pitch or accuracy of thread.

For left-hand thread, suffix "L" is added to bearing numbers. eg.: NPHS20L M20 x 1.5L-6H:

**NPOS..**

Ball: Gcr15 Steel, heat treated HRC58~64;  
Precision ground polished

Body: Carbon steel, zinc plated, chromate treated

Race: Nylon polymer

Sliding contact surfaces: Steel/Nylon

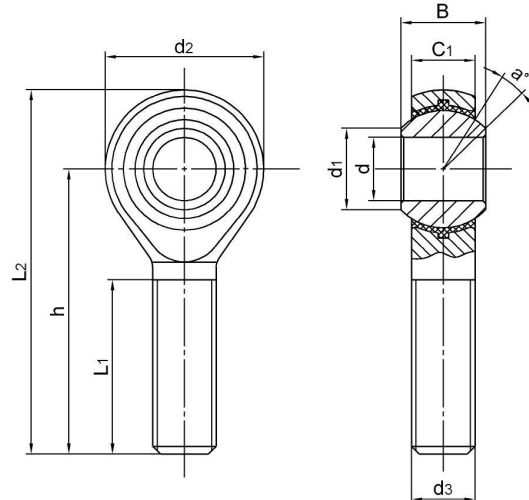

Bearing No.	Dimensions(mm)									Ball dia	a° mis. angle	Load ratings (KN)		weight ≈ Kg
	d <sub>H7</sub>	B	C <sub>1</sub>	d <sub>1</sub>	d <sub>2</sub>	d <sub>3-6g</sub>	h	L <sub>1</sub>	L <sub>2</sub>			Dynamic	Static	
NPOS5	5	8	6	7.7	16	M5	33	20	41	11.11	13	2.5	4.6	0.012
NPOS6	6	9	6.75	8.9	18	M6	36	22	45	12.7	13	3.2	6.9	0.019
NPOS8	8	12	9	10.3	22	M8	42	25	53	15.87	14	5.4	12.6	0.032
NPOS10	10	14	10.5	12.9	26	M10	48	29	61	19.05	13	7.5	16.6	0.054
NPOS12	12	16	12	15.4	30	M12	54	33	69	22.22	13	10	22	0.085
NPOS14	14	19	13.5	16.8	34	M14	60	36	77	25.4	16	13	27.8	0.126
NPOS16	16	21	15	19.3	38	M16	66	40	85	28.58	15	16	34.5	0.185
NPOS18	18	23	16.5	21.8	42	M18x1.5	72	44	93	31.75	15	19.5	40.8	0.260
NPOS20	20	25	18	24.3	46	M20x1.5	78	47	101	34.92	14	23	46.5	0.340
NPOS22	22	28	20	25.8	50	M22x1.5	84	51	109	38.1	15	29	52.6	0.435
NPOS25	25	31	22	29.5	60	M24x2	94	57	124	42.86	15	40.5	74.1	0.650
NPOS28	28	35	25	32.29	66	M27x2	103	62	136	47.63	15	46.1	88.7	0.875
NPOS30	30	37	25	34.8	70	M30x2	110	66	145	50.8	17	54.3	94	1.070

Can supply rod ends with different pitch or accuracy of thread.

For left-hand thread, suffix "L" is added to bearing numbers. eg.: NPOS20L M20 x 1.5L-6H:



## SI..E & SI..ES

Body: Carbon steel Zinc plated, chromate treated

SI..E: Mounted with GE..E type of radial spherical plain bearings.

SI..ES: Mounted with GE..ES type of radial spherical plain bearings.

Sliding contact surfaces: Steel/Steel

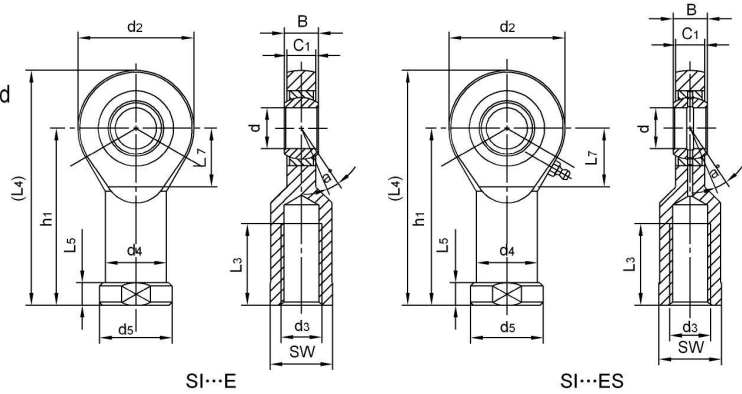

Bearing No.	Dimensions(mm)													Ball dia	a° mis. angle	Load ratings (KN)		Weight ≈ kg
	d	B	C1	d2	d3-6H	h1	L3	L4	L5	L7	d4	d5	W			Dynamic	Static	
SI5E <sup>1)</sup>	5	6	4.5	21	M5	30	11	40.5	5	11.5	11	13	11	10	13	3.4	8.1	0.021
SI6E <sup>1)</sup>	6	6	4.5	21	M6	30	11	40.5	5	11.5	11	13	11	10	13	3.4	8.1	0.021
SI8E <sup>1)</sup>	8	8	6.5	24	M8	36	15	48	5	13	13	16	13	13	15	5.5	12.9	0.039
SI10E <sup>1)</sup>	10	9	7.5	29	M10	43	20	57.5	6.5	15	16	19	16	16	12	8.1	17.6	0.061
SI12E <sup>1)</sup>	12	10	8.5	34	M12	50	22	67	7	18	18	22	19	18	10	10	24.5	0.096
SI15ES	15	12	10.5	40	M14	61	30	81	8	21	21	26	21	22	8	16	36	0.162
SI17ES	17	14	11.5	46	M16	67	32	90	10	23	25	29	27	25	10	21	45	0.233
SI20ES	20	16	13.5	53	M20x1.5	77	38	103.5	10	25.5	28	34	30	29	9	30	60	0.324
SI25ES	25	20	18	64	M24x2	94	45	126	12	33	35	42	36	35.5	7	48	83	0.625
SI30ES	30	22	20	73	M30x2	110	54	146.5	15	37.5	42	50	46	40.7	6	62	110	0.976
SI35ES	35	25	22	82	M36x3	125	60	166	15	40	48	58	55	47	6	79	146	1.52
SI40ES	40	28	24	92	M39x3	142	65	188	18	47	52	65	60	53	7	99	180	2.06
SI45ES	45	32	28	102	M42x3	145	65	196	20	52	58	70	65	60	7	127	240	2.72
SI50ES	50	35	31	112	M45x3	160	68	216	20	57	62	75	70	66	6	156	290	3.57
SI60ES	60	44	39	135	M52x3	175	70	242.5	20	68.5	70	88	80	80	6	245	450	5.63
SI70ES	70	49	43	160	M56x4	200	80	280	20	81	80	98	85	92	6	313	610	8.33
SI80ES	80	55	48	180	M64x4	230	85	320	25	91	95	110	95	105	6	400	750	13.04

<sup>1)</sup> Can not be relubricated.

Can supply rod ends with different pitch or accuracy of thread.

For left-hand thread, suffix "L" is added to bearing numbers. eg.: SIL20ES M20 x 1.5L-6H:



**SA..E & SA..ES**

Body: carbon steel Zinc plated, chromate treated

SA..E: Mounted with GE..E type of radial spherical plain bearings.

SA..ES: Mounted with GE..ES type of radial spherical plain bearings.

Sliding contact surfaces: Steel/Steel

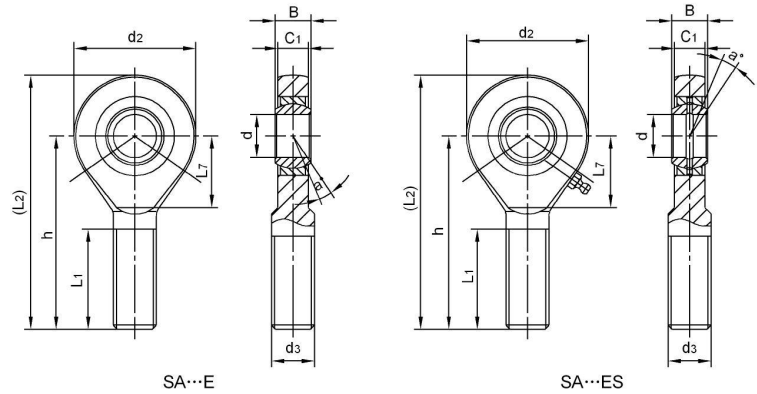

Bearing No.	Dimensions(mm)									Ball dia	a° mis. angle	Load ratings (KN)		Weight ≈ kg
	d	B	C1	d2	d3-6g	h	L1	L2	L7			Dynamic	Static	
SA6E <sup>1)</sup>	6	6	4.5	21	M6	36	16	46.5	12	10	13	3.4	6.9	0.017
SA8E <sup>1)</sup>	8	8	6.5	24	M8	42	21	54	13	13	15	5.5	12.9	0.029
SA10E <sup>1)</sup>	10	9	7.5	29	M10	48	26	62.5	16	16	12	8.1	17.6	0.044
SA12E <sup>1)</sup>	12	10	8.5	34	M12	54	28	71	18	18	10	10	24.5	0.066
SA15ES	15	12	10.5	40	M14	63	34	83	22	22	8	16	36	0.121
SA17ES	17	14	11.5	46	M16	69	36	92	24	25	10	21	45	0.172
SA20ES	20	16	13.5	53	M20x1.5	78	43	104.5	27	29	9	30	60	0.283
SA25ES	25	20	18	64	M24x2	94	53	126	33	35.5	7	48	83	0.504
SA30ES	30	22	20	73	M30x2	110	65	146.5	37.5	40.7	6	62	110	0.835
SA35ES	35	25	22	82	M36x3	140	82	181	41	47	6	79	146	1.41
SA40ES	40	28	24	92	M39x3	150	86	196	47	53	7	99	180	1.86
SA45ES	45	32	28	102	M42x3	163	92	214	52	60	7	127	240	2.57
SA50ES	50	35	31	112	M45x3	185	104	241	60	66	6	156	290	3.58
SA60ES	60	44	39	135	M52x3	210	115	277.5	75.5	80	6	245	450	5.73
SA70ES	70	49	43	160	M56x4	235	125	315	95	92	6	313	610	7.94
SA80ES	80	55	48	180	M64x4	270	140	360	105.5	105	6	400	750	12.06

<sup>1)</sup>Can not be relubricated.

Can supply rod ends with different pitch or accuracy of thread.

For left-hand thread, suffix"L" is added to bearing numbers. eg.: SAL20ES M20 x 1.5L-6g:

## SI..C & SI..ET-2RS

Body: Carbon steel Zinc plated, chromate treated

SI..C: Mounted with GE..C type of radial spherical plain bearings.

SI..ET-2RS: Mounted with GE..ET-2RS type of radial spherical plain bearings.

Sliding contact surfaces: SI..C Steel/PTFE composite  
SI..ET-2RS Steel/PTFE fabric

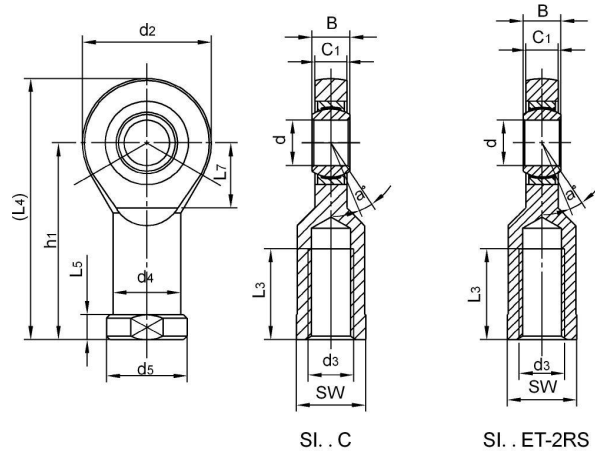

Bearing No.	Dimensions(mm)													Ball dia	a° mis. angle	Load ratings (KN)		Weight ≈ kg
	d	B	C1	d2	d3-6H	h1	L3	L4	L5	L7	d4	d5	W			Dynamic	Static	
SI5C	5	6	4.5	21	M5	30	11	40.5	5	11.5	11	13	11	10	13	3.6	8.1	0.021
SI6C	6	6	4.5	21	M6	30	11	40.5	5	11.5	11	13	11	10	13	3.6	8.1	0.021
SI8C	8	8	6.5	24	M8	36	15	48	5	13	13	16	13	13	15	5.8	12.9	0.039
SI10C	10	9	7.5	29	M10	43	20	57.5	6.5	15	16	19	16	16	12	8.6	17.6	0.061
SI12C	12	10	8.5	34	M12	50	22	67	7	18	18	22	19	18	10	11	24.5	0.096
SI15C SI15ET-2RS	15	12	10.5	40	M14	61	30	81	8	21	21	26	21	22	8	18	36	0.162
SI17C SI17ET-2RS	17	14	11.5	46	M16	67	32	90	10	23	25	29	27	25	10	22	45	0.233
SI20C SI20ET-2RS	20	16	13.5	53	M20x1.5	77	38	103.5	10	25.5	28	34	30	29	9	31	60	0.324
SI25C SI25ET-2RS	25	20	18	64	M24x2	94	45	126	12	33	35	42	36	35.5	7	51	83	0.625
SI30C SI30ET-2RS	30	22	20	73	M30x2	110	54	146.5	15	37.5	42	50	46	40.7	6	65	110	0.976
SI35ET-2RS	35	25	22	82	M36x3	125	60	166	15	40	48	58	55	47	6	112	146	1.52
SI40ET-2RS	40	28	24	92	M39x3	142	65	188	18	47	52	65	60	53	7	140	180	2.06
SI45ET-2RS	45	32	28	102	M42x3	145	65	196	20	52	58	70	65	60	7	180	240	2.72
SI50ET-2RS	50	35	31	112	M45x3	160	68	216	20	57	62	75	70	66	6	220	290	3.57
SI60ET-2RS	60	44	39	135	M52x3	175	70	242.5	20	68.5	70	88	80	80	6	345	450	5.63
SI70ET-2RS	70	49	43	160	M56x4	200	80	280	20	81	80	98	85	92	6	440	610	8.33
SI80ET-2RS	80	55	48	180	M64x4	230	85	320	25	91	95	110	95	105	6	567	750	13.04

Can supply rod ends with different pitch or accuracy of thread.

For left-hand thread, suffix "L" is added to bearing numbers. eg.: SIL20ET-2RS M20 x 1.5L-6H:

**SA..C & SA..ET-2RS**

Body: Carbon steel Zinc plated, chromate treated

SA..C: Mounted with GE..C type of radial spherical plain bearings.

SA..ET-2RS: Mounted with GE..ET-2RS type of radial spherical plain bearings.

Sliding contact surfaces: SA..C Steel/PTFE composite  
SA..ET-2RS Steel/PTFE fabric

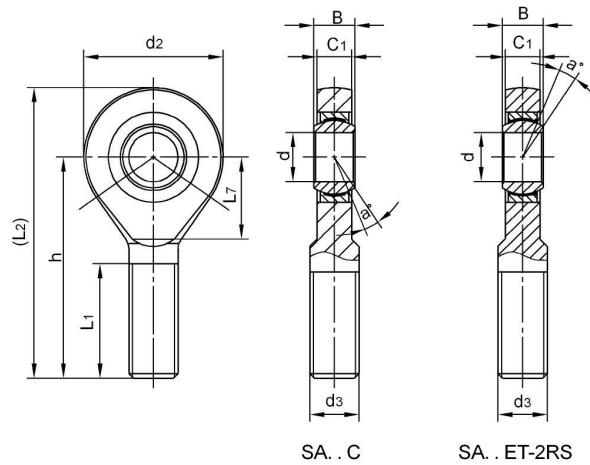

Bearing No.	Dimensions(mm)									Ball dia	a° mis. angle	Load ratings (KN)		Weight ≈ kg
	d	B	C1	d2	d3-6g	h	L1	L2	L7			Dynamic	Static	
SA5C	5	6	4.5	21	M5	36	16	46.5	12	10	13	3.6	4.6	0.017
SA6C	6	6	4.5	21	M6	36	16	46.5	12	10	13	3.6	6.9	0.017
SA8C	8	8	6.5	24	M8	42	21	54	13	13	15	5.8	12.9	0.029
SA10C	10	9	7.5	29	M10	48	26	62.5	16	16	12	8.6	17.6	0.044
SA12C	12	10	8.5	34	M12	54	28	71	18	18	10	11	24.5	0.066
SA15C SA15ET-2RS	15	12	10.5	40	M14	63	34	83	22	22	8	18	36	0.121
SA17C SA17ET-2RS	17	14	11.5	46	M16	69	36	92	24	25	10	22	45	0.172
SA20C SA20ET-2RS	20	16	13.5	53	M20x1.5	78	43	104.5	27	29	9	31	60	0.283
SA25C SA25ET-2RS	25	20	18	64	M24x2	94	53	126	33	35.5	7	51	83	0.504
SA30C SA30ET-2RS	30	22	20	73	M30x2	110	65	146.5	37.5	40.7	6	65	110	0.835
SA35ET-2RS	35	25	22	82	M36x3	140	82	181	41	47	6	112	146	1.41
SA40ET-2RS	40	28	24	92	M39x3	150	86	196	47	53	7	140	180	1.86
SA45ET-2RS	45	32	28	102	M42x3	163	92	214	52	60	7	180	240	2.57
SA50ET-2RS	50	35	31	112	M45x3	185	104	241	60	66	6	220	290	3.58
SA60ET-2RS	60	44	39	135	M52x3	210	115	277.5	75.5	80	6	345	450	5.73
SA70ET-2RS	70	49	43	160	M56x4	235	125	315	95	92	6	440	610	7.94
SA80ET-2RS	80	55	48	180	M64x4	270	140	360	105.5	105	6	567	750	12.06

Can supply rod ends with different pitch or accuracy of thread.

For left-hand thread, suffix "L" is added to bearing numbers. eg.: SAL20ET-2RS M20 x 1.5L-6g:

## PHSB..

Ball: Gcr15 Steel, heat treated, HRC56min;

precision ground, polished, hard

chromium plated

Body: Carbon steel, zinc plated,chromate treated

Race: Brass

Sliding contact surfaces: Steel/Brass

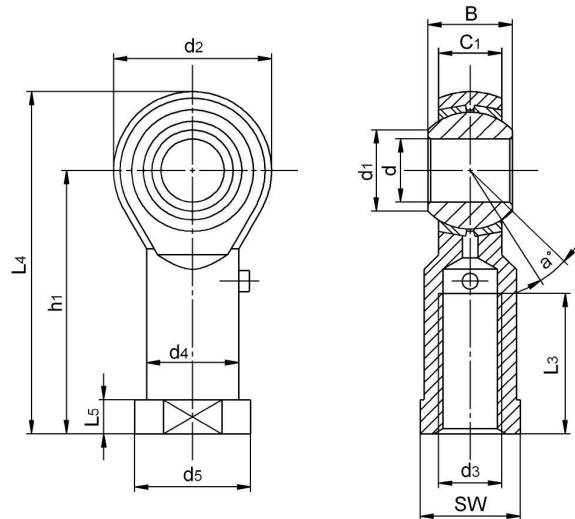

Bearing No.	Dimensions(mm)													Ball dia	a° mis. angle	Load ratings (KN)		weight ≈ kg
	d <sup>+0.038 -0.012</sup>	B	C1	d1	d2	d3 <sub>UNF-2B</sub>	h1	L3	(L4)	L5	d4	d5	SW			Dynamic Cr	Static Cor	
PHSB3	4.826	7.92	6.35	7.77	15.88	10-32	26.97	12.7	34.91	4.75	7.92	10.31	7.92	11.11	10	2.8	7.4	0.015
PHSB4	6.35	9.53	7.14	9.02	19.05	1/4-28	33.32	17.45	42.85	4.75	9.52	11.89	9.53	12.7	13	4.8	11.2	0.025
PHSB5	7.938	11.10	8.74	11.35	22.23	5/16-24	34.93	17.45	46.03	4.75	11.1	12.7	11.1	15.87	10	5.9	13.8	0.036
PHSB6	9.525	12.7	10.31	13.13	25.4	3/8-24	41.28	20.62	53.98	6.35	14.27	17.45	14.27	18.26	9	8.2	18.2	0.061
PHSB7	11.112	14.27	11.1	14.88	28.58	7/16-20	46.02	23.8	60.3	6.35	15.88	19.05	15.88	20.62	11	10	22	0.081
PHSB8	12.7	15.88	12.7	17.73	33.32	1/2-20	53.98	26.97	70.64	6.35	19.05	22.22	19.05	23.8	9	15	31.7	0.133
PHSB10	15.875	19.05	14.27	21.31	38.1	5/8-18	63.5	34.92	82.55	7.92	22.22	25.4	22.22	28.57	11	18	35.1	0.190
PHSB12	19.05	22.23	17.45	24.84	44.45	3/4-16	73.03	39.67	95.25	7.92	25.4	28.58	25.4	33.33	10	27	49.6	0.285
PHSB16	25.4	34.93	25.4	32.23	69.85	5/4-12	104.78	53.98	139.7	11.1	38.1	44.45	38.1	47.62	14	60	101	1.000

Can supply rod ends with different pitch or accuracy of thread.

For left-hand thread, suffix"L" is added to bearing numbers. eg.: PHSB12L 3/4-16L



**POSB..**

Ball: Gcr15 Steel, heat treated,HRC56min;  
 precision ground, polished, hard  
 chromium plated  
 Body: Carbon steel, zinc plated,chromate treated  
 Race: Brass  
 Sliding contact surfaces: Steel/Brass

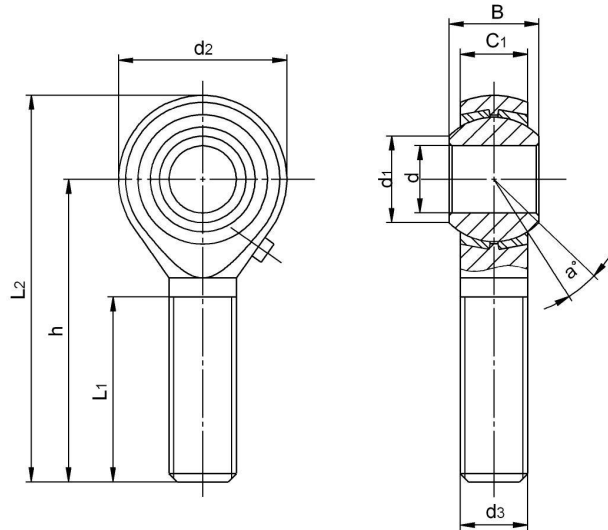

Bearing No.	Dimensions(mm)									Ball dia	a° mis. angle	Load ratings (KN)		weight ≈ kg
	d <sup>+0.038</sup> <sub>-0.012</sub>	B	C <sub>1</sub>	d <sub>1</sub>	d <sub>2</sub>	d <sub>3</sub> UNF-2A	h	L <sub>1</sub>	L <sub>2</sub>			Dynamic	Static	
POSB3	4.826	7.92	6.35	7.77	15.88	10-32	31.75	19.05	39.69	11.11	10	2.8	3.8	0.013
POSB4	6.35	9.53	7.14	9.02	19.05	1/4-28	39.67	25.4	49.2	12.7	13	4.8	6.4	0.022
POSB5	7.938	11.10	8.74	11.35	22.23	5/16-24	47.63	31.75	58.75	15.87	10	5.9	8.7	0.037
POSB6	9.525	12.7	10.31	13.13	25.4	3/8-24	49.22	31.75	61.92	18.26	9	8.2	12.4	0.055
POSB7	11.11	14.27	11.1	14.88	28.58	7/16-20	53.98	34.93	68.27	20.62	11	10	17	0.078
POSB8	12.7	15.88	12.7	17.73	33.32	1/2-20	61.92	38.1	78.58	23.8	9	15	23.4	0.120
POSB10	15.88	19.05	14.27	21.31	38.1	5/8-18	66.68	41.28	85.73	28.57	11	18	26.7	0.180
POSB12	19.05	22.23	17.45	24.84	44.45	3/4-16	73.02	44.45	95.25	33.33	10	27	36.6	0.290
POSB16	25.4	34.93	25.4	32.23	69.85	5/4-12	104.78	53.98	139.7	47.62	14	60	101	1.100

Can supply rod ends with different pitch or accuracy of thread.

For left-hand thread, suffix"L" is added to bearing numbers. eg.: POSB12L 3/4-16L

**CF..**

Ball: Gcr15 Steel, heat treated HRC56min;  
precision ground, polished, hard  
chromium plated

Body: Carbon steel, zinc plated,chromate treated

Sliding contact surfaces: Steel/Steel

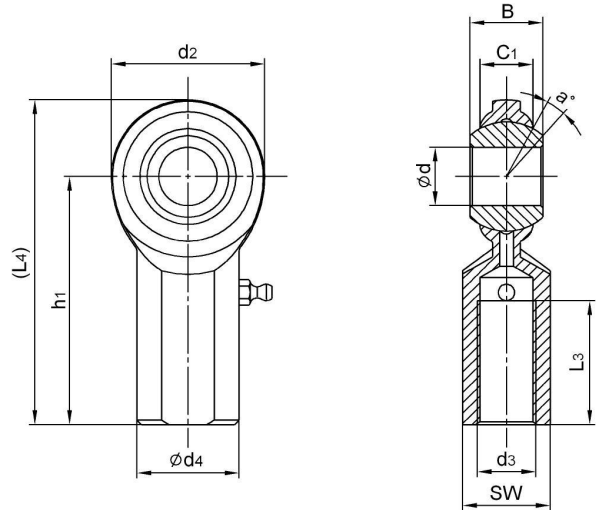

Bearing No.	Dimensions(mm/inches)										Ball dia	a° mis. angle	Load ratings (KN)	weight ≈ kg
	d <sup>+0.038</sup> <sub>-0.012</sub>	B	C1	d2	d3 UNF-2B	h1	L3	(L4)	d4	SW				
CF3	4.826	7.92	5.94	15.88	10-32	26.97	11.11	34.91	10.31	7.92	11.11	13	7.6	0.182
	0.1900	0.312	0.234	0.625		1.062	0.437	1.375	0.406	0.312	0.437			
CF4	6.35	9.53	6.35	19.05	1/4-28	33.32	14.28	42.85	11.89	9.52	12.7	18	9.9	0.226
	0.2500	0.375	0.250	0.750		1.312	0.562	1.687	0.468	0.375	0.500			
CF5	7.938	11.1	7.92	22.23	5/16-24	34.92	15.88	46.03	12.7	11.1	15.88	14	12.7	0.362
	0.3125	0.437	0.312	0.875		1.375	0.625	1.812	0.500	0.437	0.625			
CF6	9.525	12.7	9.11	25.4	3/8-24	41.28	19.05	53.98	17.45	14.27	18.26	14	17	0.059
	0.3750	0.500	0.359	1.000		1.625	0.750	2.125	0.687	0.562	0.719			
CF7	11.112	14.27	10.31	28.58	7/16-20	46.02	22.22	60.3	19.05	15.88	20.62	13	21	0.081
	0.4375	0.562	0.406	1.125		1.812	0.875	2.375	0.750	0.625	0.812			
CF8	12.7	15.88	11.5	33.33	1/2-20	53.98	25.4	70.64	22.22	19.05	23.8	12	27.5	0.131
	0.5000	0.625	0.453	1.312		2.125	1.000	2.781	0.875	0.750	0.937			
CF10	15.875	19.05	12.29	38.1	5/8-18	63.5	31.75	82.55	25.4	22.22	28.58	16	29.9	0.195
	0.6250	0.750	0.484	1.500		2.5	1.250	3.250	1.000	0.875	1.125			
CF12	19.05	22.23	15.06	44.45	3/4-16	73.02	38.1	95.25	28.58	25.4	33.33	14	44.2	0.294
	0.7500	0.875	0.593	1.750		2.875	1.500	3.75	1.125	1.000	1.312			
CF16	25.4	34.93	25.4	69.85	5/4-12	104.78	53.98	139.7	41.28	38.1	47.62	14	129.1	0.925
	1.0000	1.375	1.000	2.750		4.125	2.125	5.5	1.625	1.500	1.875			

Note: For grease fittings add "Z" to suffix example: CF6Z

Can supply rod ends with different pitch or accuracy of thread.

For left-hand thread, suffix "L" is added to bearing numbers. eg.: CFL12 3/4-16L

**CM..**

Ball: Gcr15 Steel, heat treated, HRC56min;  
precision ground, polished, hard chromium plated

Body: Carbon steel, zinc plated,chromate treated

Sliding contact surfaces: Steel/Steel

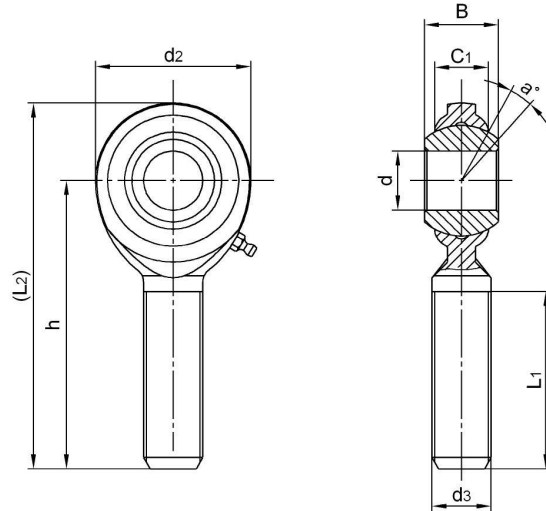

Bearing No.	Dimensions(mm/inches)								Ball dia	a° mis. angle	Load ratings (KN)	weight ≈ kg
	d <sup>+0.038</sup> / <sub>-0.012</sub>	B	C1	d2	d3 UNF-2A	h	L1	(L2)				
CM3	4.826	7.92	5.94	15.88	10-32	31.75	19.05	39.69	11.112	13	4.4	0.136
	0.1900	0.312	0.234	0.625		1.250	0.750	1.562	0.437			
CM4	6.35	9.53	6.35	19.05	1/4-28	39.67	25.4	49.2	12.7	18	8.2	0.018
	0.2500	0.375	0.250	0.750		1.562	1.000	1.937	0.500			
CM5	7.938	11.10	7.92	22.23	5/16-24	47.63	31.75	58.75	15.875	14	12.7	0.317
	0.3125	0.437	0.312	0.875		1.875	1.250	2.312	0.625			
CM6	9.525	12.7	9.11	25.4	3/8-24	49.22	31.75	61.92	18.263	14	17	0.498
	0.3750	0.500	0.359	1.000		1.938	1.250	2.687	0.719			
CM7	11.11	14.27	10.31	28.58	7/16-20	53.98	34.93	68.27	20.625	13	21	0.068
	0.4375	0.562	0.406	1.125		2.125	1.375	2.678	0.812			
CM8	12.7	15.88	11.5	33.32	1/2-20	61.92	38.1	78.58	23.8	12	27.5	0.108
	0.5000	0.625	0.453	1.312		2.438	1.500	3.093	0.937			
CM10	15.875	19.05	12.29	38.1	5/8-18	66.68	41.28	85.73	28.575	16	29.9	0.163
	0.6250	0.750	0.484	1.500		2.625	1.625	3.375	1.125			
CM12	19.05	22.23	15.06	44.45	3/4-16	73.02	44.45	95.25	33.338	14	44.2	0.258
	0.7500	0.875	0.593	1.750		2.875	1.750	3.750	1.312			
CM14	22.225	22.23	15.06	50.8	7/8-14	85.73	47.63	111.1	33.338	14	74.7	0.408
	0.8750	0.875	0.593	2.000		3.375	1.875	4.375	1.312			
CM16	25.4	34.93	25.4	69.85	5/4-12	104.78	53.98	139.7	47.625	14	129.1	0.964
	1.0000	1.375	1.000	2.750		4.125	2.125	5.500	1.875			

Note: For grease fittings add "Z" to suffix example: CM6Z

Can supply rod ends with different pitch or accuracy of thread.

For left-hand thread, suffix"L" is added to bearing numbers. eg.: CML12 3/4-16L



## CF..T

Ball: Gcr15 Steel, heat treated, HRC56min;  
precision ground, polished hard  
chromium plated

Body: Carbon steel zinc plated,chromate treated

Race: PTFE composite or PTFE fabric

Sliding contact surfaces: Steel/PTFE

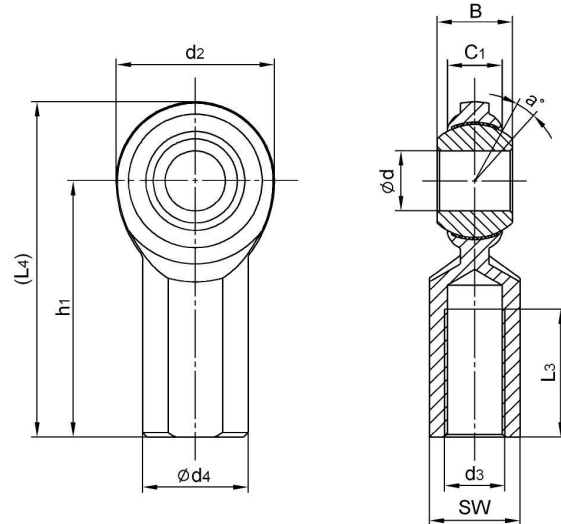

Bearing No.	Dimensions(mm/inches)										Ball dia	a° mis. angle	Load ratings (KN)	weight ≈ kg
	d <sup>+0.038</sup> / <sub>-0.012</sub>	B	C1	d2	d3 UNF-2B	h1	L3	(L4)	d4	SW				
CF3T	4.826	7.92	5.94	15.88	10-32	26.97	11.11	34.91	10.31	7.92	11.11	13	5.8	0.018
	0.1900	0.312	0.234	0.625		1.062	0.437	1.375	0.406	0.312	0.437			
CF4T	6.35	9.53	6.35	19.05	1/4-28	33.32	14.28	42.85	11.89	9.52	12.7	18	8.2	0.022
	0.2500	0.375	0.250	0.750		1.312	0.562	1.687	0.468	0.375	0.500			
CF5T	7.938	11.10	7.92	22.23	5/16-24	34.92	15.88	46.03	12.7	11.1	15.88	14	10.2	0.036
	0.3125	0.437	0.312	0.875		1.375	0.625	1.812	0.500	0.437	0.625			
CF6T	9.525	12.7	9.11	25.4	3/8-24	41.28	19.05	53.98	17.45	14.27	18.26	14	14	0.059
	0.3750	0.500	0.359	1.000		1.625	0.750	2.125	0.687	0.562	0.719			
CF7T	11.112	14.27	10.31	28.58	7/16-20	46.02	22.22	60.3	19.05	15.88	20.62	13	17.6	0.081
	0.4375	0.562	0.406	1.125		1.812	0.875	2.375	0.750	0.625	0.812			
CF8T	12.7	15.88	11.5	33.32	1/2-20	53.98	25.4	70.64	22.22	19.05	23.8	12	23.7	0.131
	0.500	0.625	0.453	1.312		2.125	1.000	2.781	0.875	0.750	0.937			
CF10T	15.875	19.05	12.29	38.1	5/8-18	63.5	31.75	82.55	25.4	22.22	28.58	16	25.7	0.195
	0.6250	0.750	0.484	1.500		2.5	1.250	3.250	1.000	0.875	1.125			
CF12T	19.05	22.23	15.06	44.45	3/4-16	73.02	38.1	95.25	28.58	25.4	33.33	14	42.4	0.294
	0.7500	0.875	0.593	1.750		2.875	1.500	3.75	1.125	1.000	1.312			

Can supply rod ends with different pitch or accuracy of thread.

For left-hand thread, suffix "L" is added to bearing numbers. eg.: CFL12T 3/4-16L

**CM..T**

Ball: Gcr15 Steel, heat treated, HRC56min;  
precision ground polished,hard chromium plated

Body: Carbon steel zinc plated,chromate treated

Race: PTFE composite or PTFE fabric

Sliding contact surfaces: Steel/PTFE

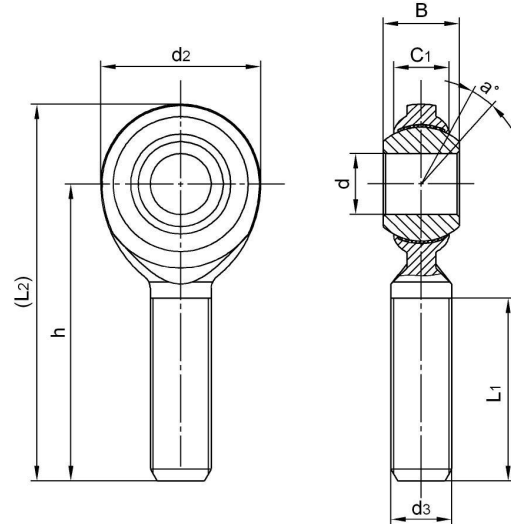

Bearing No.	Dimensions(mm/inches)								Ball dia	a° mis. angle	Load ratings (KN)	weight ≈ kg
	d <sup>+0.038</sup> / <sub>-0.012</sub>	B	C1	d2	d3 UNF-2A	h	L1	(L2)				
CM3T	4.826	7.92	5.94	15.88	10-32	31.75	19.05	39.69	11.112	13	4.4	0.013
	0.1900	0.312	0.234	0.625		1.250	0.750	1.562	0.437			
CM4T	6.35	9.53	6.35	19.05	1/4-28	39.67	25.4	49.2	12.7	18	8.2	0.018
	0.2500	0.375	0.250	0.750		1.562	1.000	1.937	0.500			
CM5T	7.938	11.10	7.92	22.23	5/16-24	47.63	31.75	58.75	15.875	14	12.7	0.031
	0.3125	0.437	0.312	0.875		1.875	1.250	2.312	0.625			
CM6T	9.525	12.7	9.11	25.4	3/8-24	49.22	31.75	61.92	18.263	14	14	0.049
	0.3750	0.500	0.359	1.000		1.938	1.250	2.437	0.719			
CM7T	11.112	14.27	10.31	28.58	7/16-20	53.98	34.93	68.27	20.625	13	17.6	0.068
	0.4375	0.562	0.406	1.125		2.125	1.375	2.678	0.812			
CM8T	12.7	15.88	11.5	33.32	1/2-20	61.92	38.1	78.58	23.8	12	23.7	0.108
	0.5000	0.625	0.453	1.312		2.438	1.500	3.093	0.937			
CM10T	15.875	19.05	12.29	38.1	5/8-18	66.68	41.28	85.73	28.575	16	25.7	0.163
	0.6250	0.750	0.484	1.500		2.625	1.625	3.375	1.125			
CM12T	19.05	22.23	15.06	44.45	3/4-16	73.02	44.45	95.25	33.338	14	42.4	0.258
	0.7500	0.875	0.593	1.750		2.875	1.750	3.750	1.312			
CM14T	22.225	22.23	15.06	50.8	7/8-14	85.73	47.63	111.1	33.338	14	70.8	0.408
	0.8750	0.875	0.593	2.000		3.375	1.875	4.375	1.312			

Can supply rod ends with different pitch or accuracy of thread.

For left-hand thread, suffix"L" is added to bearing numbers. eg.: CML12T 3/4-16L

## CF..TY

Ball: Gcr15 Steel, heat treated, HRC56min;  
precision ground, polished hard  
chromium plated

Body: Carbon steel zinc plated,chromate treated

Liner: PTFE composite or PTFE fabric

Stud: Low carbon steel, zinc plated

Sliding contact surfaces: Steel/PTFE Composite  
or Steel/PTFE fabric

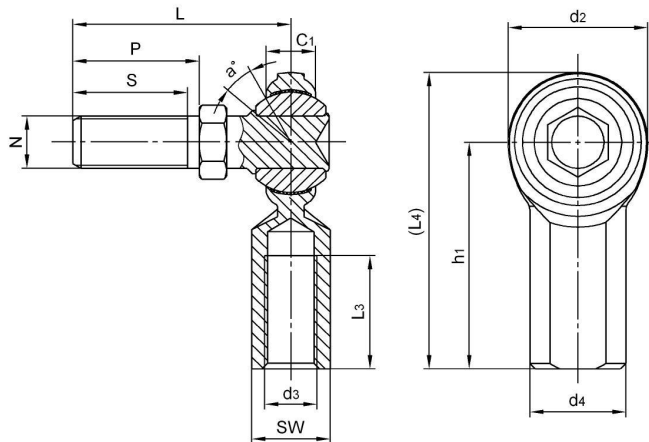

Bearing No.	Dimensions(mm/inches)												Ball dia	a° mis. angle	Load ratings (KN)	weight ≈ kg
	d2	C1	d3 UNF-2B	d4	SW	h1	L3	(L4)	N UNF-2A	S	P	L				
CF3TY	15.88	5.94	10-32	10.31	7.92	26.97	11.1	34.91	10-32	11.1	12.7	25.8	11.11	22	4.4	0.022
	0.625	0.234		0.406	0.312	1.062	0.437	1.375		0.437	0.500	1.016	7/16			
CF4TY	19.05	6.35	1/4-28	11.89	9.52	33.32	14.27	42.85	1/4-28	12.7	14.27	26.18	12.7	20	8.2	0.027
	0.750	0.250		0.468	0.375	1.312	0.562	1.687		0.500	0.562	1.031	1/2			
CF5TY	22.23	7.92	5/16-24	12.7	11.1	34.92	15.88	46.03	5/16-24	15.06	17.45	30.96	15.88	21	10.2	0.048
	0.875	0.312		0.500	0.437	1.375	0.625	1.812		0.593	0.687	1.219	5/8			
CF6TY	25.4	9.11	3/8-24	17.45	14.27	41.28	19.05	53.98	3/8-24	20.62	23	39.67	18.26	23	14	0.077
	1.000	0.359		0.687	0.562	1.625	0.750	2.125		0.812	0.906	1.562	23/32			
CF7TY	28.58	10.31	7/16-20	19.05	15.88	46.02	22.22	60.3	7/16-20	23.8	26.97	44.45	20.62	22	17.6	0.122
	1.125	0.406		0.750	0.625	1.812	0.875	2.375		0.937	1.062	1.750	13/16			
CF8TY	33.33	11.5	1/2-20	22.22	19.05	53.98	25.4	70.64	1/2-20	25.4	28.58	50.8	23.8	24	23.7	0.181
	1.312	0.453		0.875	0.750	2.125	1.000	2.781		1.000	1.125	2.000	15/16			
CF10TY	38.1	12.3	5/8-18	25.4	22.22	63.5	31.75	82.55	5/8-18	34.93	38.1	63.5	28.58	26	25.7	0.308
	1.500	0.484		1.000	0.875	2.5	1.250	3.250		1.375	1.500	2.500	9/8			
CF12TY	44.45	15.06	3/4-16	28.58	25.4	73.03	38.1	95.25	3/4-16	41.28	46.02	76.2	33.33	23	42.4	0.503
	1.750	0.593		1.125	1.000	2.875	1.500	3.75		1.625	1.812	3.000	21/16			

Can supply rod ends with different pitch or accuracy of thread.

For left-hand thread, suffix "L" is added to bearing numbers. eg.: CFL6TY 3/8-24L

**CM..TY**

Ball: Gcr15 Steel, heat treated, HRC56min;  
precision ground, polished, hard  
chromium plated

Body: Carbon steel zinc plated,chromate treated

Liner: PTFE composite or PTFE fabric

Stud: Low carbon steel, zinc plated

Sliding contact surfaces: Steel/PTFE Composite  
or Steel/PTFE fabric

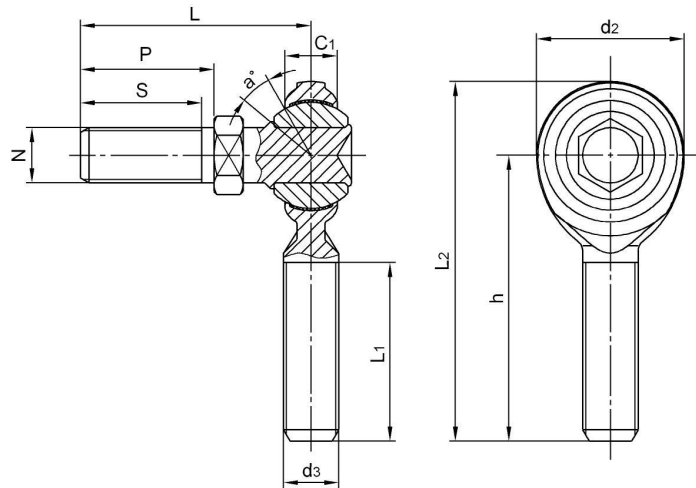

Bearing No.	Dimensions(mm/inches)										Ball dia	a° mis. angle	Load ratings (KN)	weight ≈ kg
	d2	C1	d3 UNF-2A	h	L1	(L4)	N UNF-2A	S	P	L				
CM3TY	15.88	5.94	10-32	31.75	19.05	39.69	10-32	11.1	12.7	25.8	11.11	22	4.4	0.018
	0.625	0.234		1.250	0.750	1.562		0.437	0.500	1.016	7/16			
CM4TY	19.05	6.35	1/4-28	39.67	25.4	49.2	1/4-28	12.7	14.27	26.18	12.7	20	8.2	0.022
	0.750	0.250		1.562	1.000	1.937		0.500	0.562	1.031	1/2			
CM5TY	22.23	7.92	5/16-24	47.63	31.75	58.75	5/16-24	15.06	17.45	30.96	15.88	21	10.2	0.045
	0.875	0.312		1.875	1.250	2.312		0.593	0.687	1.219	5/8			
CM6TY	25.4	9.11	3/8-24	49.23	31.75	61.92	3/8-24	20.62	23	39.67	18.26	23	14	0.068
	1.000	0.359		1.938	1.250	2.437		0.812	0.906	1.562	23/32			
CM7TY	28.58	10.31	7/16-20	53.98	34.93	68.27	7/16-20	23.8	26.97	44.45	20.62	22	17.6	0.108
	1.125	0.406		2.125	1.375	2.678		0.937	1.062	1.750	13/16			
CM8TY	33.33	11.5	1/2-20	61.93	38.1	78.58	1/2-20	25.4	28.58	50.8	23.8	24	23.7	0.158
	1.312	0.453		2.438	1.500	3.093		1.000	1.125	2.000	15/16			
CM10TY	38.1	12.3	5/8-18	66.68	41.28	85.73	5/8-18	34.93	38.1	63.5	28.57	26	25.7	0.276
	1.500	0.484		2.625	1.625	3.375		1.375	1.500	2.500	9/8			
CM12TY	44.45	15.06	3/4-16	73.03	44.45	95.25	3/4-16	41.28	46.02	76.2	33.33	23	42.4	0.467
	1.750	0.593		2.875	1.750	3.750		1.625	1.812	3.000	21/16			

Can supply rod ends with different pitch or accuracy of thread.

For left-hand thread, suffix"L" is added to bearing numbers. eg.: CML6TY 3/8-24L

**F..**

Ball: Gcr15 Steel, heat treated, HRC56min;  
precision ground, polished, hard  
chromium plated

Body: Carbon steel zinc plated,chromate treated

Race: Brass

Sliding contact surfaces: Steel/Brass

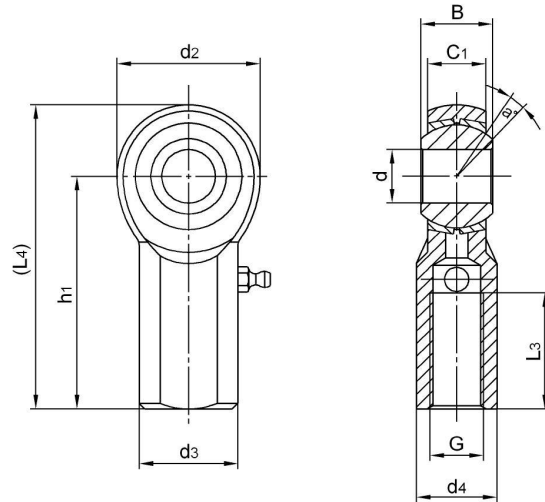

Bearing No.	Dimensions(mm/inches)										Ball dia	a° mis. angle	Load ratings (KN)	weight ≈ kg
	d <sup>+0.038</sup> <sub>-0.012</sub>	B	C1	d2	d3 <sub>UNF-2B</sub>	h1	L3	(L4)	d4	SW				
F3	4.826	7.92	6.35	15.88	10-32	26.97	11.11	34.91	10.31	7.92	11.11	10	7.6	0.018
	0.1900	0.312	0.250	0.625		1.062	0.437	1.375	0.406	0.312	0.437			
F4	6.35	9.53	7.14	19.05	1/4-28	33.32	14.28	42.85	11.89	9.52	12.7	13	11.3	0.027
	0.2500	0.375	0.281	0.750		1.312	0.562	1.687	0.468	0.375	0.500			
F5	7.938	11.10	8.74	22.23	5/16-24	34.92	15.88	46.03	12.7	11.1	15.88	10	14.5	0.04
	0.3125	0.437	0.344	0.875		1.375	0.625	1.812	0.500	0.437	0.625			
F6	9.525	12.7	10.31	25.4	3/8-24	41.28	19.05	53.98	17.45	14.27	18.26	9	18.5	0.068
	0.3750	0.500	0.406	1.000		1.625	0.750	2.125	0.687	0.562	0.719			
F7	11.112	14.27	11.1	28.58	7/16-20	46.02	22.22	60.3	19.05	15.88	20.62	11	22.3	0.09
	0.4375	0.562	0.437	1.125		1.812	0.875	2.375	0.750	0.625	0.812			
F8	12.7	15.88	12.7	33.32	1/2-20	53.98	25.4	70.64	22.22	19.05	23.8	9	32	0.149
	0.5000	0.625	0.500	1.312		2.125	1.000	2.781	0.875	0.750	0.937			
F10	15.875	19.05	14.27	38.1	5/8-18	63.5	31.75	82.55	25.4	22.22	28.58	11	35.5	0.217
	0.6250	0.750	0.562	1.500		2.5	1.250	3.250	1.000	0.875	1.125			
F12	19.05	22.23	17.45	44.45	3/4-16	73.02	38.1	95.25	28.58	25.4	33.33	10	50.2	0.326
	0.7500	0.875	0.678	1.750		2.875	1.500	3.75	1.125	1.000	1.312			
F16	25.4	34.93	25.4	69.85	5/4-12	104.78	53.98	139.7	41.28	38.1	47.62	14	164.2	0.963
	1.0000	1.375	1.000	2.750		4.125	2.125	5.5	1.625	1.500	1.875			

Note: For grease fittings add " Z" to suffix example: F6Z

Can supply rod ends with different pitch or accuracy of thread.

For left-hand thread, suffix"L" is added to bearing numbers. eg.: FL12 3/4-16L

**M..**

Ball: Gcr15 Steel, heat treated, HRC56min;  
precision ground, polished hard  
chromium plated

Body: Carbon steel, zinc plated,chromate treated

Race: Brass

Sliding contact surfaces: Steel/Brass

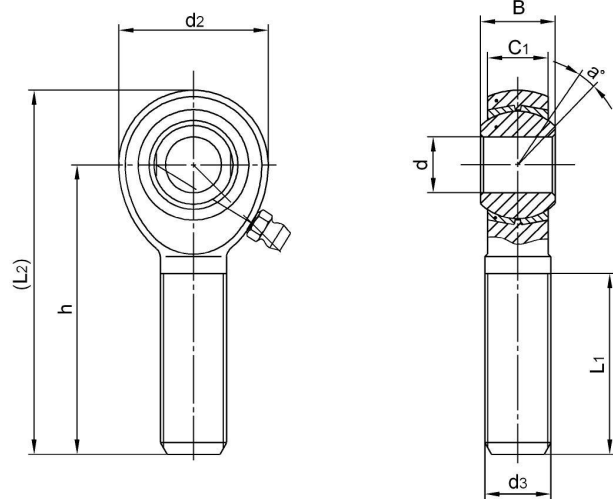

Bearing No.	Dimensions(mm/inches)								Ball dia	a° mis. angle	Load ratings (KN)	weight ≈ kg
	d <sup>+0.038</sup> <sub>-0.012</sub>	B	C1	d2	d3 UNF-2A	h	L1	(L2)				
M3	4.826	7.92	6.35	15.88	10-32	31.75	19.05	39.69	11.11	10	4.4	0.013
	0.1900	0.312	0.250	0.625		1.250	0.750	1.562	0.437			
M4	6.35	9.53	7.14	19.05	1/4-28	39.67	25.4	49.2	12.7	13	8.2	0.018
	0.2500	0.375	0.281	0.750		1.562	1.000	1.937	0.500			
M5	7.938	11.10	8.74	22.23	5/16-24	47.63	31.75	58.75	15.88	10	13.1	0.031
	0.3125	0.437	0.344	0.875		1.875	1.250	2.312	0.625			
M6	9.525	12.7	10.31	25.4	3/8-24	49.22	31.75	61.92	18.26	9	14.6	0.049
	0.3750	0.500	0.406	1.000		1.938	1.250	2.437	0.719			
M7	11.112	14.27	11.1	28.58	7/16-20	53.98	34.93	68.27	20.62	11	19.5	0.072
	0.4375	0.562	0.437	1.125		2.125	1.375	2.678	0.812			
M8	12.7	15.88	12.7	33.32	1/2-20	61.92	38.1	78.58	23.8	9	29.4	0.113
	0.5000	0.625	0.500	1.312		2.438	1.500	3.093	0.937			
M10	15.875	19.05	14.27	38.1	5/8-18	66.68	41.28	85.73	28.58	11	35.5	0.172
	0.6250	0.750	0.562	1.500		2.625	1.625	3.375	1.125			
M12	19.05	22.23	17.45	44.45	3/4-16	73.02	44.45	95.25	33.33	10	50.2	0.272
	0.7500	0.875	0.687	1.750		2.875	1.750	3.750	1.312			
M14	22.225	22.23	17.45	50.8	7/8-14	85.73	47.63	111.1	33.33	10	85	0.408
	0.8750	0.875	0.687	2.000		3.375	1.875	4.375	1.312			
M16	25.4	34.93	25.4	69.85	5/4-12	104.78	53.98	139.7	47.63	14	152.5	1.091
	1.0000	1.375	1.000	2.750		4.125	2.125	5.500	1.875			

Note: For grease fittings add " Z" to suffix example: M6Z

Can supply rod ends with different pitch or accuracy of thread.

For left-hand thread, suffix"L" is added to bearing numbers. eg.: ML12 3/4-16L

JF..

Ball: Gcr15 Steel, heat treated, HRC56min;  
precision ground, polished hard  
chromium plated

Body: Carbon steel, zinc plated, chromate treated

Race: Steel alloy, zinc plated, chromate treated

Sliding contact surfaces: Steel/Steel or

Steel/PTFE Composite

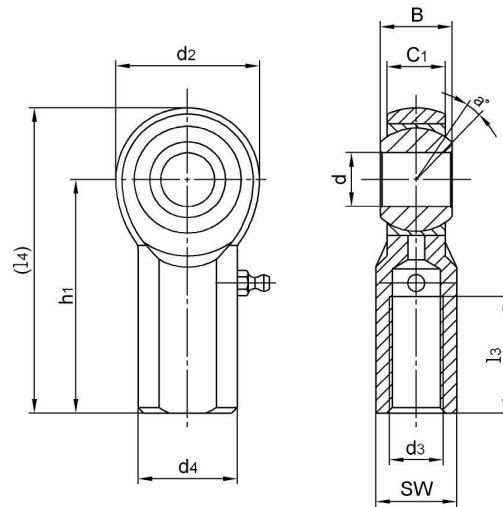

Bearing No.	Dimensions(mm/inches)										Ball dia	a° mis. angle	Load ratings (KN)	weight ≈ kg
	d <sup>+0.038</sup> <sub>-0.012</sub>	B	C <sub>1</sub>	d <sub>2</sub>	d <sub>3</sub> UNF-2B	h <sub>1</sub>	l <sub>3</sub>	(l <sub>4</sub> )	d <sub>4</sub>	SW				
JF3	4.826	7.92	6.35	15.88	10-32	26.97	11.11	34.91	10.31	7.92	11.11	10	5.4	0.018
	0.1900	0.312	0.250	0.625		1.062	0.437	1.375	0.406	0.312	0.437			
JF4	6.35	9.53	7.14	19.05	1/4-28	33.32	14.28	42.85	11.89	9.52	12.7	13	9.0	0.027
	0.2500	0.375	0.281	0.750		1.312	0.562	1.687	0.468	0.375	0.500			
JF5	7.938	11.10	8.74	22.23	5/16-24	34.92	15.88	46.03	12.7	11.1	15.88	10	11.1	0.04
	0.3125	0.437	0.344	0.875		1.375	0.625	1.812	0.500	0.437	0.625			
JF6	9.525	12.7	10.31	25.4	3/8-24	41.28	19.05	53.98	17.45	14.27	18.26	9	13.3	0.068
	0.3750	0.500	0.406	1.000		1.625	0.750	2.125	0.687	0.562	0.719			
JF7	11.11	14.27	11.1	28.58	7/16-20	46.02	22.22	60.3	19.05	15.88	20.62	11	18.5	0.09
	0.4375	0.562	0.437	1.125		1.812	0.875	2.375	0.750	0.625	0.812			
JF8	12.7	15.88	12.7	33.32	1/2-20	53.98	25.4	70.64	22.22	19.05	23.8	9	29.1	0.149
	0.500	0.625	0.500	1.312		2.125	1.000	2.781	0.875	0.750	0.937			
JF10	15.875	19.05	14.27	38.1	5/8-18	63.5	31.75	82.55	25.4	22.22	28.58	11	31.2	0.217
	0.6250	0.750	0.562	1.500		2.5	1.250	3.250	1.000	0.875	1.125			
JF12	19.05	22.23	17.45	44.45	3/4-16	73.03	38.1	95.25	28.58	25.4	33.33	10	44.8	0.326
	0.7500	0.875	0.687	1.750		2.875	1.500	3.75	1.125	1.000	1.312			
JF16	25.4	34.93	25.4	69.85	5/4-12	104.78	53.98	139.7	41.28	38.1	47.62	14		0.963
JF16-1**	1.0000	1.375	1.000	2.750	1-14	4.125	2.125	5.5	1.625	1.500	1.875		155.4	1.093
JF16-2**					1-12									1.093

Notes: For grease fittings add " Z" to suffix. Example: JF6Z  
For studs add " Y" to suffix. Example: JF5Y  
For teflon liner add "T" to suffix. Example: JF12T

Can supply rod ends with different pitch or accuracy of thread.

For left-hand thread, suffix "L" is added to bearing numbers. eg.: JFL12T 3/4-16L



**JM..**

Ball: Gcr15 Steel, heat treated, HRC56min;  
 precision ground, polished, hard chromium plated  
 Body: Carbon steel zinc plated,chromate treated  
 Race: Steel alloy, zinc plated, chromate treated  
 Sliding contact surfaces: Steel/Steel or  
 Steel/PTFE composite

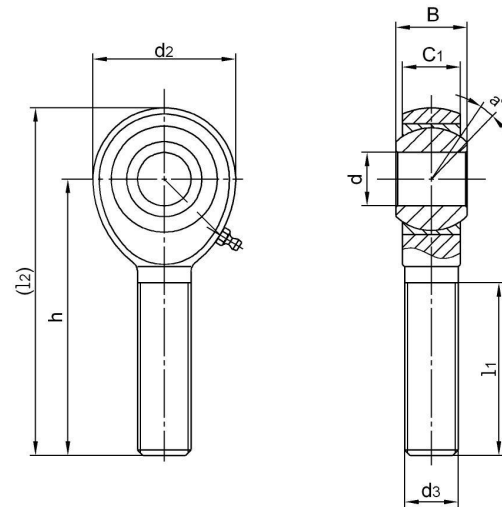

Bearing No.	Dimensions(mm/inches)								Ball dia	a° mis. angle	Load ratings (KN)	weight ≈ kg
	d <sup>+0.038</sup> <sub>-0.012</sub>	B	C1	d2	d3 UNF-2A	h	l1	(l2)				
JM3	4.826	7.92	6.35	15.88	10-32	31.75	19.05	39.69	11.11	10	4.4	0.013
	0.1900	0.312	0.250	0.625		1.250	0.750	1.562	0.437			
JM4	6.35	9.53	7.14	19.05	1/4-28	39.67	25.4	49.2	12.7	13	8.2	0.018
	0.2500	0.375	0.281	0.750		1.562	1.000	1.937	0.500			
JM5	7.938	11.1	8.74	22.23	5/16-24	47.63	31.75	58.75	15.88	10	11.1	0.031
	0.3125	0.437	0.344	0.875		1.875	1.250	2.312	0.625			
JM6	9.525	12.7	10.31	25.4	3/8-24	49.22	31.75	61.92	18.26	9	13.3	0.049
	0.3750	0.500	0.406	1.000		1.938	1.250	2.437	0.719			
JM7	11.112	14.27	11.1	28.58	7/16-20	53.98	34.93	68.27	20.62	11	18.5	0.072
	0.4375	0.562	0.437	1.125		2.125	1.375	2.678	0.812			
JM8	12.7	15.88	12.7	33.32	1/2-20	61.92	38.1	78.58	23.8	9	29.1	0.113
	0.5000	0.625	0.500	1.312		2.438	1.500	3.093	0.937			
JM10	15.875	19.05	14.27	38.1	5/8-18	66.68	41.28	85.73	28.58	11	31.2	0.172
	0.6250	0.750	0.562	1.500		2.625	1.625	3.375	0.937			
JM12	19.05	22.23	17.45	44.45	3/4-16	73.02	44.45	95.25	28.58	10	44.8	0.272
	0.7500	0.875	0.687	1.750		2.875	1.750	3.750	1.125			
JM14	25.4	22.23	17.45	50.8	7/8-14	85.73	47.63	111.1	33.33	10	85	0.408
	0.8750	0.875	0.687	2.000		3.375	1.875	4.375	1.312			
JM16	25.4	34.93	25.4	69.85	5/4-12	104.78	53.98	139.7	47.63	14	155.4	1.091
JM16-1**	1.0000	1.375	1.000	2.750	1-14	4.125	2.125	5.500	1.875			0.964
JM16-2**					12							0.964

Note: For grease fittings add "Z" to suffix. Example: JM6Z  
 For studs add "Y" to suffix. Example: JM5Y  
 For teflon liner add "T" to suffix. Example: JM12T

Can supply rod ends with different pitch or accuracy of thread.

For left-hand thread, suffix"L" is added to bearing numbers. eg.: JML12T 3/4-16L



**SPHSB..EC**

Ball: 440C Stainless steel, heat treated  
 HRC56 min, precision ground, polished  
 Body: 304 Stainless steel  
 Race: PTFE composite  
 Sliding contact surfaces: Steel/PTFE composite

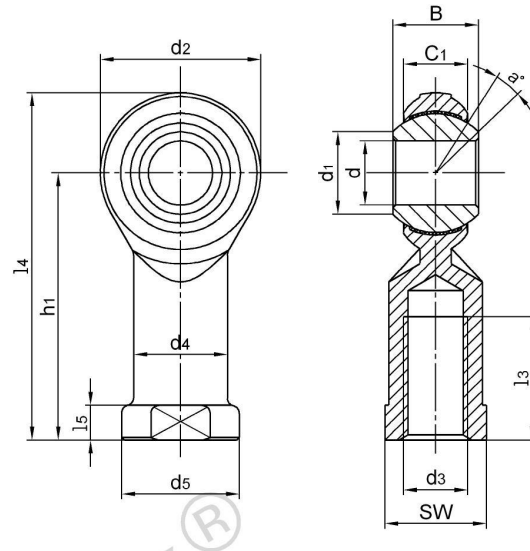

Bearing No.	Dimensions(mm)													Ball dia	a° mis. angle	Load ratings		weight ≈ kg
	d <sup>+0.038 -0.012</sup>	B	C1	d1	d2	d3 UNF-2B	h1	l3	(l4)	L5	d4	d5	SW			Dynamic Cr	Static Cor	
SPHSB3EC	4.826	7.92	6.35	7.77	15.88	10-32	26.97	12.7	34.91	4.75	7.92	10.31	7.92	11.11	10	3.3	6.6	0.015
SPHSB4EC	6.35	9.53	7.14	9.02	19.05	1/4-28	33.32	17.45	42.85	4.75	9.52	11.89	9.52	12.7	13	4.8	11	0.025
SPHSB5EC	7.938	11.10	8.74	11.35	22.23	5/16-24	34.92	17.45	46.03	4.75	11.1	12.7	11.1	15.87	10	5.9	12	0.036
SPHSB6EC	9.525	12.7	10.31	13.13	25.4	3/8-24	41.28	20.62	53.98	6.35	14.27	17.45	14.27	18.26	9	8.2	18.2	0.061
SPHSB7EC	11.11	14.27	11.1	14.88	28.58	7/16-20	46.02	23.8	60.3	6.35	15.88	19.05	15.88	20.62	11	10	21.5	0.081
SPHSB8EC	12.7	15.88	12.7	17.73	33.32	1/2-20	53.98	26.97	70.64	6.35	19.05	22.22	19.05	23.8	9	15	30.6	0.133
SPHSB10EC	15.88	19.05	14.27	21.31	38.1	5/8-18	63.5	34.92	82.55	7.92	22.22	25.4	22.22	28.57	11	18	34.1	0.190
SPHSB12EC	19.05	22.23	17.45	24.84	44.45	3/4-16	73.03	39.67	95.25	7.92	25.4	28.58	25.4	33.33	10	27	47.9	0.285

Can supply rod ends with different pitch or accuracy of thread.  
 For left-hand thread, suffix"L" is added to bearing numbers. eg.: SPHSB12ECL 3/4-16L

**SPOSB..EC**

Ball: 440C Stainless steel, heat treated, HRC56 min,

Body: 304 Stainless steel

Race: PTFE composite

Sliding contact surfaces: Steel/PTFE composite

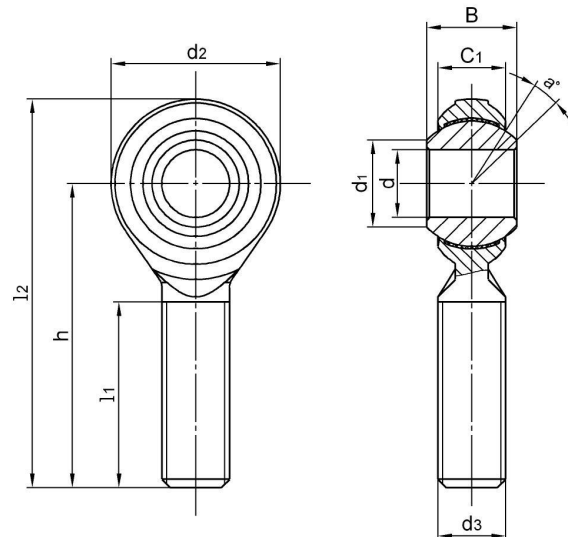

Bearing No.	Dimensions(mm)									Ball dia	a° mis. angle	Load ratings KN		weight ≈ kg
	d <sup>+0.038 -0.012</sup>	B	C1	d1	d2	d3 <sub>UNF-2A</sub>	h	l1	l2			Dynamic	Static	
SPOSB3EC	4.826	7.92	6.35	7.77	15.88	10-32	31.75	19.05	39.69	11.11	10	2.8	4.4	0.013
SPOSB4EC	6.35	9.53	7.14	9.02	19.05	1/4-28	39.67	25.4	49.2	12.7	13	4.8	8.2	0.022
SPOSB5EC	7.938	11.10	8.74	11.35	22.23	5/16-24	47.63	31.75	58.75	15.87	10	5.9	13.1	0.037
SPOSB6EC	9.525	12.7	10.31	13.13	25.4	3/8-24	49.22	31.75	61.92	18.26	9	8.2	18.2	0.055
SPOSB7EC	11.11	14.27	11.1	14.88	28.58	7/16-20	53.98	34.93	68.28	20.62	11	10	21.5	0.078
SPOSB8EC	12.7	15.88	12.7	17.73	33.32	1/2-20	61.92	38.1	78.59	23.8	9	15	30.6	0.120
SPOSB10EC	15.88	19.05	14.27	21.31	38.1	5/8-18	66.68	41.28	85.73	28.57	11	18	34.1	0.180
SPOSB12EC	19.05	22.23	17.45	24.84	44.45	3/4-16	73.02	44.45	95.25	33.33	10	27	47.9	0.290

Can supply rod ends with different pitch or accuracy of thread.

For left-hand thread, suffix"L" is added to bearing numbers. eg.: SPOSB12ECL 3/4-16L

## SCF..T(SPHSB..EC)

Ball: 440C Stainless steel, heat treated, HRC 56min  
precision ground, polished

Body: 304 Stainless steel

Race: PTFE composite or PTFE fabric

Sliding contact surfaces: Steel/PTFE

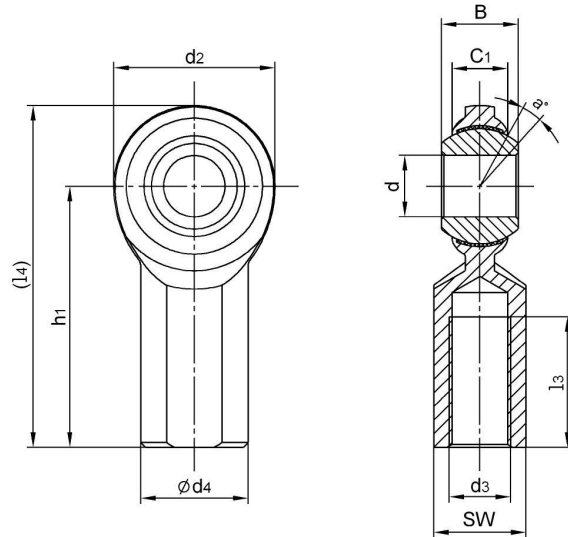

Bearing No.	Dimensions(mm/inches)										Ball dia	a° mis. angle	Load ratings (KN)	weight ≈ kg
	d <sup>+0.03</sup> <sub>-0.01</sub>	B	C1	d2	d3 <sub>UNF-2B</sub>	h1	l3	(L4)	d4	SW				
SCF3T	4.826	7.92	5.94	15.88	10-32	26.97	11.11	34.91	10.31	7.92	11.11	13	5.8	0.018
	0.1900	0.312	0.234	0.625		1.062	0.437	1.375	0.406	0.312	0.437			
SCF4T	6.35	9.53	6.35	19.05	1/4-28	33.32	14.28	42.85	11.89	9.52	12.7	18	8.2	0.022
	0.2500	0.375	0.250	0.750		1.312	0.562	1.687	0.468	0.375	0.500			
SCF5T	7.938	11.10	7.92	22.23	5/16-24	34.92	15.88	46.03	12.7	11.1	15.88	14	10.2	0.036
	0.3125	0.437	0.312	0.875		1.375	0.625	1.812	0.500	0.437	0.625			
SCF6T	9.525	12.7	9.11	25.4	3/8-24	41.28	19.05	53.98	17.45	14.27	18.26	14	14	0.059
	0.3750	0.500	0.359	1.000		1.625	0.750	2.125	0.687	0.562	0.719			
SCF7T	11.112	14.27	10.31	28.58	7/16-20	46.02	22.22	60.3	19.05	15.88	20.62	13	17.6	0.081
	0.4375	0.562	0.406	1.125		1.812	0.875	2.375	0.750	0.625	0.812			
SCF8T	12.7	15.88	11.5	33.32	1/2-20	53.98	25.4	70.64	22.22	19.05	23.8	12	23.7	0.131
	0.5000	0.625	0.453	1.312		2.125	1.000	2.781	0.875	0.750	0.937			
SCF10T	15.875	19.05	12.29	38.1	5/8-18	63.5	31.75	82.55	25.4	22.22	28.58	16	25.7	0.195
	0.6250	0.750	0.484	1.500		2.5	1.250	3.250	1.000	0.875	1.125			
SCF12T	19.05	22.23	15.06	44.45	3/4-16	73.03	38.1	95.25	28.58	25.4	33.33	14	42.4	0.294
	0.7500	0.875	0.593	1.750		2.875	1.500	3.75	1.125	1.000	1.312			

Can supply rod ends with different pitch or accuracy of thread.

For left-hand thread, suffix "L" is added to bearing numbers. eg.: SCFL12T 3/4-16L



## SCM..T(SPOSB..EC)

Ball: 440C Stainless steel, heat treated, HRC 56min  
precision ground, polished

Body: 304 Stainless steel

Race: PTFE composite or PTFE fabric

Sliding contact surfaces: Steel/PTFE

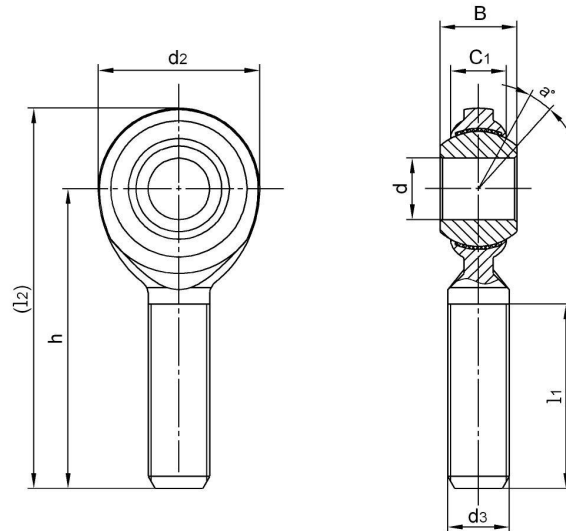

Bearing No.	Dimensions(mm/inches)								Ball dia	a° mis. angle	Load ratings (KN)	weight ≈ kg
	d <sup>+0.03</sup> / <sub>-0.01</sub>	B	C1	d2	d3 UNF-2A	h	l1	(l2)				
SCM3T	4.826	7.92	5.94	15.88	10-32	31.75	19.05	39.69	11.112	13	4.4	0.013
	0.1900	0.312	0.234	0.625		1.250	0.750	1.562	0.437			
SCM4T	6.35	9.53	6.35	19.05	1/4-28	39.67	25.4	49.2	12.7	18	8.2	0.018
	0.2500	0.375	0.250	0.750		1.562	1.000	1.937	0.500			
SCM5T	7.938	11.10	7.92	22.23	5/16-24	47.63	31.75	58.75	15.875	14	12.7	0.031
	0.3125	0.437	0.312	0.875		1.875	1.250	2.312	0.625			
SCM6T	9.525	12.7	9.11	25.4	3/8-24	49.22	31.75	61.92	18.263	14	14	0.049
	0.3750	0.500	0.359	1.000		1.938	1.250	2.437	0.719			
SCM7T	11.11	14.27	10.31	28.58	7/16-20	53.98	34.93	68.27	20.625	13	17.6	0.068
	0.4375	0.562	0.406	1.125		2.125	1.375	2.678	0.812			
SCM8T	12.7	15.88	11.5	33.32	1/2-20	61.92	38.1	78.58	23.8	12	23.7	0.108
	0.500	0.625	0.453	1.312		2.438	1.500	3.093	0.937			
SCM10T	15.875	19.05	12.29	38.1	5/8-18	66.68	41.28	85.73	28.575	16	25.7	0.163
	0.6250	0.750	0.484	1.500		2.625	1.625	3.375	1.125			
SCM12T	19.05	22.23	15.06	44.45	3/4-16	73.02	44.45	95.25	33.338	14	42.4	0.258
	0.7500	0.875	0.593	1.750		2.875	1.750	3.750	1.312			

Can supply rod ends with different pitch or accuracy of thread.

For left-hand thread, suffix"L" is added to bearing numbers. eg.: SCML12T 3/4-16L

## CMX.. CMX..T

Ball: Gcr15 Steel, heat treated, HRC56min;  
precision ground, polished hard  
chromium plated

Body: Alloy steel, heat treated, Black oxide coated

CMX..

Sliding contact surfaces: Steel/Steel

CMX..T

Sliding contact surfaces: Steel/PTFE Composite or fabric

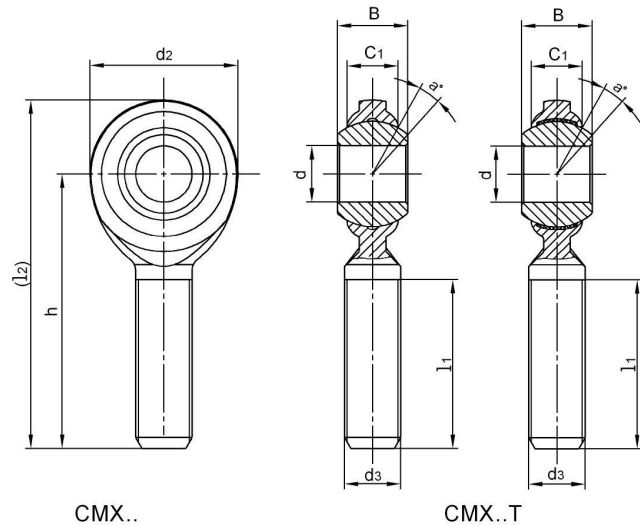

Bearing No.	Dimensions(mm/inches)								Ball dia	a° mis. angle	Load ratings (KN)	weight ≈ kg
	d	B	C <sub>1</sub>	d <sub>2</sub>	d <sub>3</sub> UNF-2A	h	l <sub>1</sub>	(l <sub>2</sub> )				
CMX8	12.7	15.88	11.5	33.32	1/2-20	61.92	38.1	78.58	23.8	12	75.6	0.108
CMX8T	0.500	0.625	0.453	1.312		2.438	1.500	3.093	0.937			
CMX10-8	12.7	19.05	12.29	38.1	5/8-18	66.68	41.28	85.73	28.57	16	80	0.136
CMX10-8T	0.5000	0.750	0.484	1.500		2.625	1.625	3.375	1.125			
CMX10	15.88	19.05	12.29	38.1	5/8-18	66.68	41.28	85.73	28.57	16	80	0.163
CMX10T	0.6250	0.750	0.484	1.500		2.625	1.625	3.375	1.125			
CMX12-8	12.7	22.23	15.06	44.45	3/4-16	73.02	44.45	95.25	33.33	14	111.2	0.258
CMX12-8T	0.5000	0.875	0.593	1.750		2.875	1.750	3.750	1.312			
CMX12-10	15.875	22.23	15.06	44.45	3/4-16	73.02	44.45	95.25	33.33	14	111.2	0.258
CMX12-10T	0.6250	0.875	0.593	1.750		2.875	1.750	3.750	1.312			
CMX12	19.05	22.23	15.06	44.45	3/4-16	73.02	44.45	95.25	33.33	14	111.2	0.258
CMX12T	0.7500	0.875	0.593	1.750		2.875	1.750	3.750	1.312			

Can supply rod ends with different pitch or accuracy of thread.

For left-hand thread, suffix"L" is added to bearing numbers. eg.: CMXL12T 3/4-16L



**JFX  
JFX..T**

Ball: Gcr15 Steel, heat treated, HRC56min;  
precision ground, polished, hard  
chromium plated

Body: Steel alloy, heat treated, zinc plated, chromate treated

Race: Steel alloy, heat treated, zinc plated, chromate treated

Sliding contact surfaces: Steel/Steel or Steel/PTFE Composite

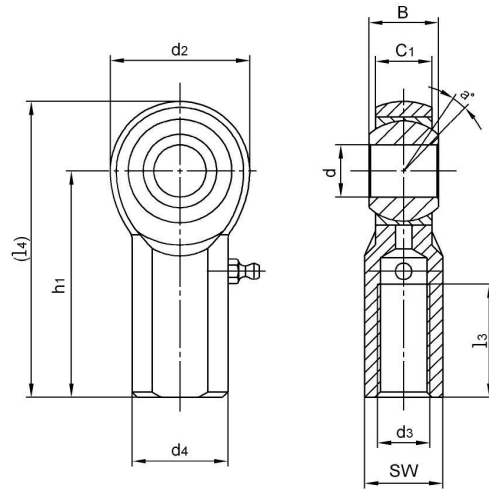

Bearing No.	Dimensions(mm/inches)										Ball dia	a° mis. angle	Load ratings (KN)	weight ≈ kg
	d <sup>+0.038</sup> <sub>-0.012</sub>	B	C1	d2	d3 UNF-2B	h1	l3	(L4)	d4	SW				
JFX3	4.826	7.92	6.35	15.88	10-32	26.97	11.11	34.91	10.31	7.92	11.11	10	16.6	0.018
	0.1900	0.312	0.250	0.625		1.062	0.437	1.375	0.406	0.312	0.437			
JFX4	6.35	9.53	7.14	19.05	1/4-28	33.32	14.28	42.85	11.89	9.52	12.7	13	27.5	0.027
	0.2500	0.375	0.281	0.750		1.312	0.562	1.687	0.468	0.375	0.500			
JFX5	7.938	11.10	8.74	22.23	5/16-24	34.92	15.88	46.03	12.7	11.1	15.88	10	33.9	0.040
	0.3125	0.437	0.344	0.875		1.375	0.625	1.812	0.500	0.437	0.625			
JFX6	9.525	12.7	10.31	25.4	3/8-24	41.28	19.05	53.98	17.45	14.27	18.26	9	42.4	0.068
	0.3750	0.500	0.406	1.000		1.625	0.750	2.125	0.687	0.562	0.719			
JFX7	11.112	14.27	11.1	28.58	7/16-20	46.02	22.22	60.3	19.05	15.88	20.62	11	45.7	0.090
	0.4375	0.562	0.437	1.125		1.812	0.875	2.375	0.750	0.625	0.812			
JFX8	12.7	15.88	12.7	33.32	1/2-20	53.98	25.4	70.64	22.22	19.05	23.8	9	68.2	0.149
	0.5000	0.625	0.500	1.312		2.125	1.000	2.781	0.875	0.750	0.937			
JFX10	15.875	19.05	14.27	38.1	5/8-18	63.5	31.75	82.55	25.4	22.22	28.58	11	79.8	0.217
	0.6250	0.750	0.562	1.500		2.5	1.250	3.250	1.000	0.875	1.125			
JFX12	19.05	22.23	17.45	44.45	3/4-16	73.03	38.1	95.25	28.58	25.4	33.33	10	124.9	0.326
	0.7500	0.875	0.687	1.750		2.875	1.500	3.75	1.125	1.000	1.312			
JFX16	25.4	34.93	25.4	69.85	5/4-12	104.78	53.98	139.7	41.28	38.1	47.62	14	338.9	0.963
	1.0000	1.375	1.000	2.750		4.125	2.125	5.5	1.625	1.500	1.875			
JFX16-1**	25.4	34.93	25.4	69.85	1-14	104.78	53.98	139.7	41.28	38.1	47.62	14	338.9	1.093
	1.0000	1.375	1.000	2.750		4.125	2.125	5.5	1.625	1.500	1.875			

Notes: For grease fittings add "Z" to suffix. Example: JFX6Z  
For studs add "Y" to suffix. Example: JFX5Y  
For teflon liner add "T" to suffix. Example: JFX12T

Can supply rod ends with different pitch or accuracy of thread.

For left-hand thread, suffix"L" is added to bearing numbers. eg.: JFXL12T 3/4-16L

## JMX.. JMX..T

Ball: Gcr15 Steel, heat treated, HRC56min;  
precision ground, polished, hard  
chromium plated

Body: Steel alloy, heat treated, zinc  
plated, chromate treated

Race: Steel alloy, heat treated, zinc  
plated, chromate treated

Sliding contact surfaces: Steel/Steel or  
Steel/PTFE Composite

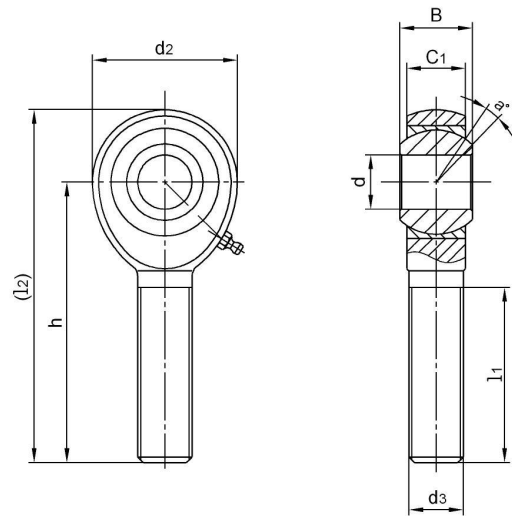

Bearing No.	Dimensions(mm/inches)								Ball dia	a° mis. angle	Load ratings (KN)	weight ≈ kg
	d <sup>+0.038 -0.012</sup>	B	C <sub>1</sub>	d <sub>2</sub>	d <sub>3</sub> UNF-2A	h	l <sub>1</sub>	(l <sub>2</sub> )				
JMX3	4.826	7.92	6.35	15.88	10-32	31.75	19.05	39.69	11.11	13	12.6	0.013
	0.1900	0.312	0.250	0.625		1.250	0.750	1.562	0.437			
JMX4	6.35	9.53	7.14	19.05	1/4-28	39.67	25.4	49.2	12.7	16	23.4	0.018
	0.2500	0.375	0.281	0.750		1.562	1.000	1.937	0.500			
JMX5	7.938	11.10	8.74	22.23	5/16-24	47.63	31.75	58.75	15.88	14	33.9	0.031
	0.3125	0.437	0.344	0.875		1.875	1.250	2.312	0.625			
JMX6	9.525	12.7	10.31	25.4	3/8-24	49.22	31.75	61.92	18.26	12	42.4	0.049
	0.3750	0.500	0.406	1.000		1.938	1.250	2.437	0.719			
JMX7	11.112	14.27	11.1	28.58	7/16-20	53.98	34.93	68.27	20.62	14	45.7	0.072
	0.4375	0.562	0.437	1.125		2.125	1.375	2.678	0.812			
JMX8	12.7	15.88	12.7	33.32	1/2-20	61.92	38.1	78.58	23.8	12	72.2	0.113
	0.5000	0.625	0.500	1.312		2.438	1.500	3.093	0.937			
JMX10	15.875	19.05	14.27	38.1	5/8-18	66.68	41.28	85.73	28.58	16	79.8	0.172
	0.6250	0.750	0.562	1.500		2.625	1.625	3.375	1.125			
JMX12	19.05	22.23	17.45	44.45	3/4-16	73.02	44.45	95.25	33.33	14	124.9	0.272
	0.7500	0.875	0.678	1.750		2.875	1.750	3.750	1.312			
JMX14	22.225	22.23	17.45	50.8	7/8-14	85.73	47.63	111.1	33.33	10	247.7	0.408
	0.8750	0.875	0.687	2.000		3.375	1.875	4.375	1.312			
JMX16	25.4	34.93	25.4	69.85	5/4-12	104.78	53.98	139.7	47.62	14	476.7	1.241
	1.0000	1.375	1.0000	2.750		4.125	2.125	5.500	1.875			
JMX16-1**	25.4	34.93	25.4	69.85	1-14	104.78	53.98	139.7	47.62	14	476.7	1.117
	1.0000	1.375	1.0000	2.750		4.125	2.125	5.500	1.875			

Notes: For grease fittings add "Z" to suffix. Example: JMX6Z

For studs add "Y" to suffix. Example: JMX5Y

For teflon liner add "T" to suffix. Example: JMX12T

Can supply rod ends with different pitch or accuracy of thread.

For left-hand thread, suffix "L" is added to bearing numbers. eg.: JMXL12T 3/4-16L



**RJM..**

Ball: Gcr15 Steel, heat treated, HRC56min;  
 precision ground, polished, hard  
 chromium plated  
 Body: Carbon steel, decorative chrome plated  
 Race: Steel alloy, heat treated, zinc plated, chromate treated  
 Sliding contact surfaces: Steel/Steel

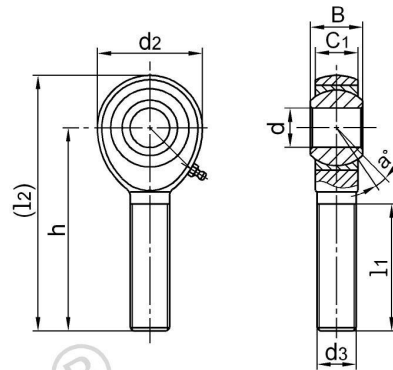

Bearing No.	Dimensions(mm/inches)									Ball dia	a° mis. angle	Load ratings (KN)	weight ≈ kg
	d <sup>+0.038</sup> <sub>-0.012</sub>	B	C <sub>1</sub>	d <sub>2</sub>	d <sub>3</sub> <sub>UNF-2A</sub>	h	l <sub>1</sub>	(l <sub>2</sub> )					
RJM4	6.35	9.53	7.14	19.05	1/4-28	39.67	25.4	49.2	12.7	13	8.2	0.018	
	0.2500	0.375	0.281	0.750		1.562	1.000	1.937	0.500				
RJM5	7.938	11.10	8.74	22.23	5/16-24	47.63	31.75	58.75	15.88	10	11.1	0.031	
	0.3125	0.437	0.344	0.875		1.875	1.120	2.312	0.625				
RJM6	9.525	12.7	10.31	25.4	3/8-24	49.22	31.75	61.92	18.26	9	13.3	0.049	
	0.3750	0.500	0.406	1.000		1.938	1.250	2.437	0.719				

**RJF..**

Ball: Gcr15 Steel, heat treated, HRC56min;  
 precision ground, polished,hard  
 chromium plated  
 Body: Carbon steel,decorative chrome plated  
 Race: Steel alloy, heat treated, zinc plated, chromate treated  
 Sliding contact surfaces: Steel/Steel

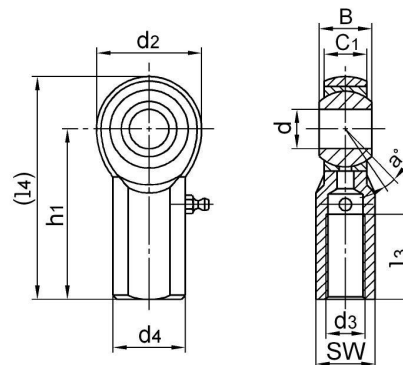

Bearing No.	Dimensions(mm/inches)										Ball dia	a° mis. angle	Load ratings (KN)	weight ≈ kg
	d <sup>+0.038</sup> <sub>-0.012</sub>	B	C <sub>1</sub>	d <sub>2</sub>	d <sub>3</sub> <sub>UNF-2B</sub>	h <sub>1</sub>	l <sub>3</sub>	(l <sub>4</sub> )	d <sub>4</sub>	SW				
RJF4	6.35	9.53	7.14	19.05	1/4-28	33.32	14.85	42.85	11.89	9.53	12.7	13	9.0	0.027
	0.2500	0.375	0.281	0.750		1.312	0.562	1.687	0.468	0.375	0.500			
RJF5	7.938	11.10	8.74	22.23	5/16-24	34.92	15.88	46.03	12.7	11.1	15.88	10	11.1	0.040
	0.3125	0.437	0.344	0.875		1.312	0.625	1.812	0.500	0.437	0.625			
RJF6	9.525	12.7	10.31	25.4	3/8-24	41.28	19.05	53.98	17.45	14.27	18.26	9	13.3	0.068
	0.3750	0.500	0.406	1.000		1.625	0.750	2.125	0.687	0.562	0.719			

Can supply rod ends with different pitch or accuracy of thread.  
 For left-hand thread, suffix"L" is added to bearing numbers. eg.: RJML6 3/4-24L; RJFL6 3/8-24L



## RJMX..T

Ball: Gcr15 Steel, heat treated, HRC56min;  
 precision ground, polished, hard  
 chromium plated

Body: Steel alloy, heat treated, bright electroless  
 nickel or hard chrome plated

Race: Steel alloy, heat treated, zinc  
 plated, chromate treated

Liner: PTFE Composite or PTFE fabric

Sliding contact surfaces: Steel/PTFE Composite

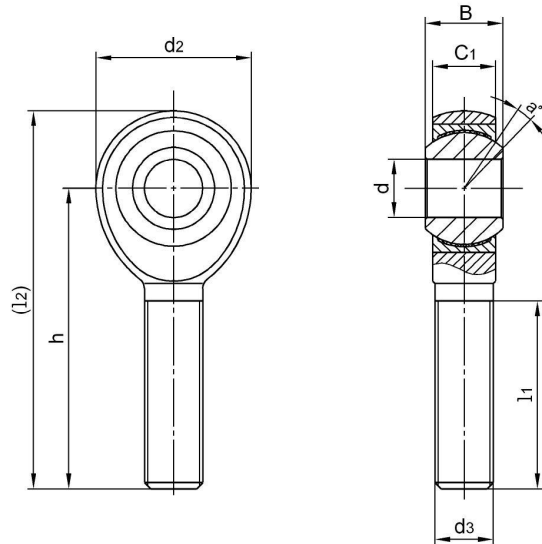

Bearing No.	Dimensions(mm/inches)								Ball dia	a° mis. angle	Load ratings (KN)	weight ≈ kg
	d <sup>+0.038</sup> <sub>-0.012</sub>	B	C <sub>1</sub>	d <sub>2</sub>	d <sub>3</sub> UNF-2A	h	l <sub>1</sub>	(l <sub>2</sub> )				
RJMX6T	9.525	12.7	10.31	25.4	3/8-24	49.22	31.75	61.92	18.26	12	42.4	0.035
	0.3750	0.500	0.406	1.000		1.938	1.250	2.437	0.719			
RJMX7T	11.112	14.27	11.1	28.58	7/16-20	53.98	34.93	68.27	20.62	14	45.7	0.041
	0.4375	0.562	0.437	1.125		2.125	1.375	2.678	0.812			
RJMX8T	12.7	15.88	12.7	33.32	1/2-20	61.92	38.1	78.58	23.8	12	72.2	0.063
	0.5000	0.625	0.500	1.312		2.438	1.500	3.093	0.937			
RJMX10T	15.875	19.05	14.27	38.1	5/8-18	66.68	41.28	85.73	28.58	16	79.8	0.108
	0.6250	0.750	0.562	1.500		2.625	1.625	3.375	1.125			
RJMX12T	19.05	22.23	17.45	44.45	3/4-16	73.02	44.45	95.25	33.33	14	124.9	0.136
	0.7500	0.875	0.687	1.750		2.875	1.750	3.750	1.312			

Can supply rod ends with different pitch or accuracy of thread.

For left-hand thread, suffix"L" is added to bearing numbers. eg.: RJMXL6T 3/8-24L

**RRSMX..T**

Ball: Gcr15 Steel, heat treated, HRC56min;  
 precision ground, polished, hard  
 chromium plated

Body: Steel alloy, heat treated, bright electroless  
 nickel or hard chrome plated

Race: Steel alloy, heat treated,  
 zinc plated, chromate treated

Liner: PTFE composite or PTFE fabric

Sliding contact surfaces: Steel/PTFE liner

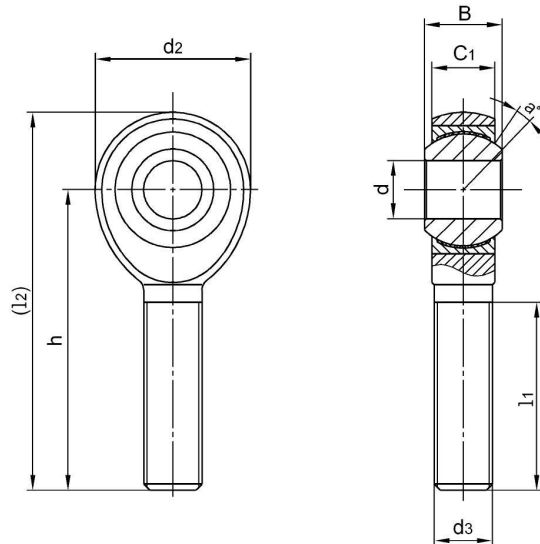

Bearing No.	Dimensions(mm/inches)								Ball dia	a° mis. angle	Load ratings (KN)	weight ≈ kg
	d <sup>+0.038</sup> / <sub>-0.012</sub>	B	C <sub>1</sub>	d <sub>2</sub>	d <sub>3</sub> UNF-2A	h	l <sub>1</sub>	(l <sub>2</sub> )				
RRSMX6T	9.525	12.7	10.31	28.58	7/16-20	53.98	34.93	68.27	18.26	12	78.3	0.072
	0.3750	0.500	0.406	1.125		2.125	1.375	2.687	0.719			
RRSMX7T	11.112	14.27	11.1	33.32	1/2-20	61.92	38.1	78.58	20.62	14	104.3	0.112
	0.4375	0.562	0.437	1.312		2.438	1.500	3.093	0.812			
RRSMX8T	12.7	15.88	12.7	38.1	5/8-18	66.68	41.28	85.73	23.8	12	139.7	0.173
	0.5000	0.625	0.5000	1.500		2.625	1.625	3.375	0.937			
RRSMX10T	15.875	19.05	14.27	44.45	3/4-16	73.03	44.45	95.25	28.58	16	180.5	0.273
	0.6250	0.750	0.562	1.750		2.875	1.750	3.75	1.125			

Can supply rod ends with different pitch or accuracy of thread.

For left-hand thread, suffix"L" is added to bearing numbers. eg.: RRS MXL6T 7/16-20L

## SJF..T

Ball: 440C Stainless steel, heat treated, HRC56 min,  
precision ground, polished

Body: 17-4Ph Stainless steel, heat treated

Race: 17-4Ph Stainless steel, heat treated

Sliding contact surfaces: Steel/PTFE composite  
or Steel/PTFE fabric

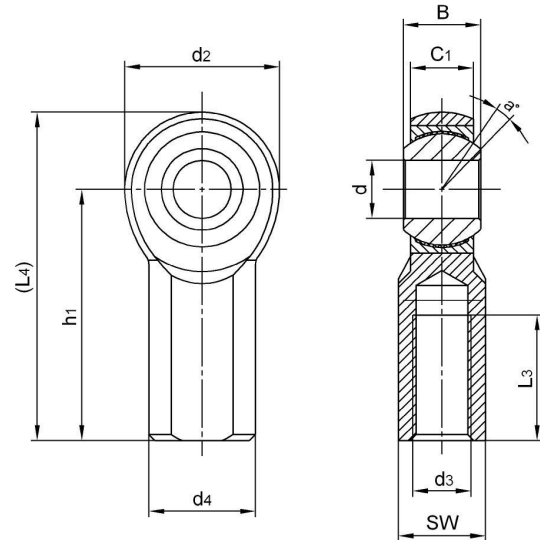

Bearing No.	Dimensions(mm/inches)										Ball dia	a° mis. angle	Load ratings (KN)	weight ≈ kg
	d <sup>+0.038</sup> / <sub>-0.012</sub>	B	C1	d2	d3 <sub>UNF-2B</sub>	h1	l1	(l2)	d4	SW				
SJF4T	6.35	9.53	7.14	20.47	1/4-28	33.32	15.88	43.55	11.89	9.52	13.48	16	21.3	0.026
	0.2500	0.375	0.281	0.806		1.312	0.625	1.714	0.468	0.375	0.531			
SJF5T	7.938	11.11	8.74	22.86	5/16-24	34.93	17.45	46.35	12.7	11.1	15.06	14	26.3	0.041
	0.3125	0.437	0.344	0.900		1.375	0.687	1.825	0.500	0.437	0.593			
SJF6T	9.525	12.7	10.31	26.03	3/8-24	41.28	22.22	54.29	17.45	14.27	17.45	12	32.7	0.068
	0.3750	0.500	0.406	1.025		1.625	0.875	2.13	0.687	0.562	0.687			
SJF7T	11.112	14.27	11.1	29.21	7/16-20	46.02	25.4	60.6	19.05	15.88	19.83	14	35.2	0.089
	0.4375	0.562	0.437	1.150		1.812	1.000	2.38	0.750	0.625	0.781			
SJF8T	12.7	15.88	12.7	33.96	1/2-20	53.98	28.58	70.96	22.22	19.05	22.22	12	55.7	0.149
	0.5000	0.625	0.500	1.337		2.125	1.125	2.97	0.875	0.750	0.875			
SJF10T	15.875	19.05	17.27	38.74	5/8-18	63.5	34.93	82.87	25.4	22.22	26.97	16	61.6	0.216
	0.6250	0.750	0.562	1.525		2.500	1.375	3.262	1.000	0.875	1.062			
SJF12T	19.05	22.23	17.45	45.09	3/4-16	73.03	41.28	95.57	28.58	25.4	31.75	14	96.3	0.327
	0.7500	0.875	0.687	1.775		2.875	1.625	3.762	1.125	1.000	1.250			

Can supply rod ends with different pitch or accuracy of thread.

For left-hand thread, suffix"L" is added to bearing numbers. eg.: SJFL6T 3/8-24L

**SJM..T**

Ball: 440C Stainless steel, heat treated HRC56 min,  
 precision ground, polished

Body: 17-4Ph Stainless steel, heat treated

Race: 17-4Ph Stainless steel, heat treated

Liner: PTFE composite or PTFE fabric

Sliding contact surfaces: Steel/PTFE composite  
 or Steel/PTFE fabric

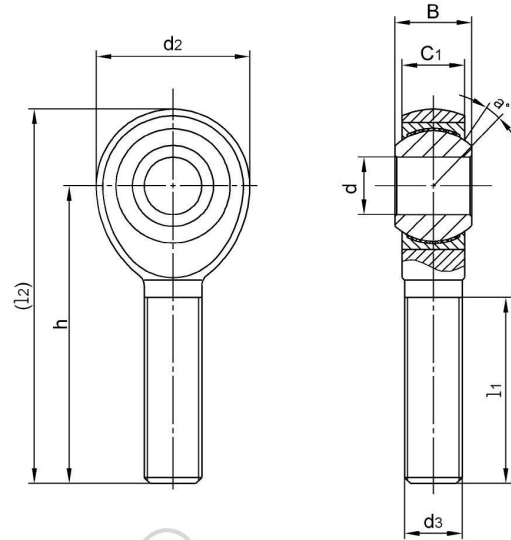

Bearing No.	Dimensions(inches)								Ball dia	a° mis. angle	Load ratings (ibs)	weight ≈ kg
	d <sup>+0.0000</sup> / <sub>-0.0005</sub>	B <sup>+0.000</sup> / <sub>-0.002</sub>	C1 <sup>+0.005</sup> / <sub>-0.005</sub>	d2 <sup>+0.010</sup> / <sub>-0.010</sub>	d3	h <sup>+0.010</sup> / <sub>-0.010</sub>	l1 <sup>+0.031</sup> / <sub>-0.031</sub>	l2				
SJM4T	0.2500	0.437	0.337	0.806	1/4-28	1.562	0.968	1.964	0.531	16	4874	0.032
SJM5T	0.3125	0.437	0.327	0.900	5/16-24	1.875	1.187	2.325	0.593	14	7196	0.039
SJM6T	0.3750	0.500	0.416	1.025	3/8-24	1.938	1.187	2.450	0.687	12	8580	0.061
SJM7T	0.4375	0.562	0.452	1.150	7/16-20	2.125	1.281	2.700	0.781	14	12000	0.083
SJM8T	0.5000	0.625	0.515	1.337	1/2-20	2.438	1.468	3.106	0.875	12	19520	0.126
SJM10T	0.6250	0.750	0.577	1.525	5/8-18	2.625	1.562	3.387	1.062	16	21920	0.192
SJM12T	0.7500	0.875	0.640	1.775	3/4-16	2.875	1.687	3.762	1.250	14	29310	0.289

Can supply rod ends with different pitch or accuracy of thread.  
 For left-hand thread, suffix"L" is added to bearing numbers. eg.: SJML6T 3/8-24L

SRSMX..T

Ball: 440C Stainless steel, heat treated, HRC56 min,  
precision ground, polished

Body: 17-4Ph Stainless steel, heat treated

Race: 17-4Ph Stainless steel, heat treated

Liner: PTFE composite or PTFE fabric

Sliding contact surfaces: Steel/PTFE composite  
or Steel/PTFE fabric

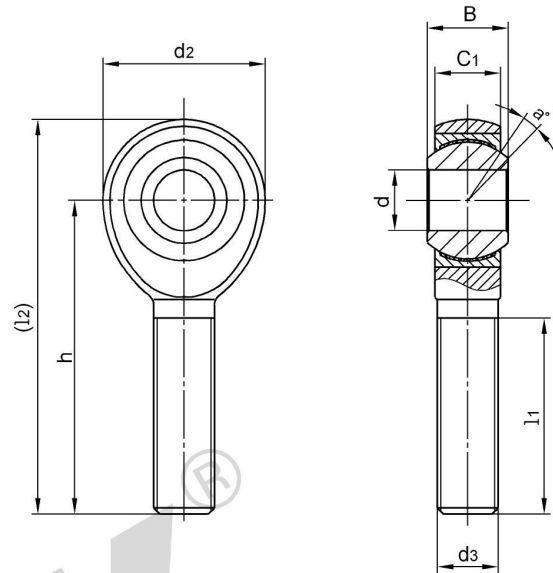

SRSM-T:STAINLESS STEEL EXTRA HEAVY DUTY SHANK

Bearing No.	Dimensions(inches)								Ball dia	a° mis. angle	Load ratings (KN)	weight ≈ kg
	d <sup>+0.0000 -0.0005</sup>	B <sup>+0.000 -0.002</sup>	C1 <sup>+0.005 -0.005</sup>	d2 <sup>+0.010 -0.010</sup>	d3 <sub>UNF-3A</sub>	h <sup>+0.010 -0.010</sup>	l1 <sup>+0.031 -0.031</sup>	(l2)				
SRSMX6T	0.3750	0.500	0.416	1.150	7/16-20	2.125	1.375	2.450	0.687	11	17610	0.072
SRSMX7T	0.4375	0.562	0.452	1.150	1/2-20	2.125	1.75	2.700	0.781	13	23470	0.112
SRSMX8T	0.500	0.625	0.515	1.337	5/8-18	2.438	1.625	3.106	0.875	12	33172	0.173
SRSMX10T	0.6250	0.750	0.577	1.525	3/4-16	2.625	1.75	3.387	1.062	14	40507	0.273

Can supply rod ends with different pitch or accuracy of thread.

For left-hand thread, suffix"L" is added to bearing numbers. eg.: SRSMXL6T 7/16-20L



**HJMX..T**

Ball: Gcr15 Steel, heat treated, HRC56min;  
 precision ground, polished, hard  
 chromium plated

Body: 4340 steel, heat treated,  
 zinc plated, chromate treated

Race: Steel alloy, zinc plated, chromate treated

Liner: PTFE composite or PTFE fabric

Sliding contact surfaces: Steel/PTFE Composite  
 or Steel/PTFE fabric

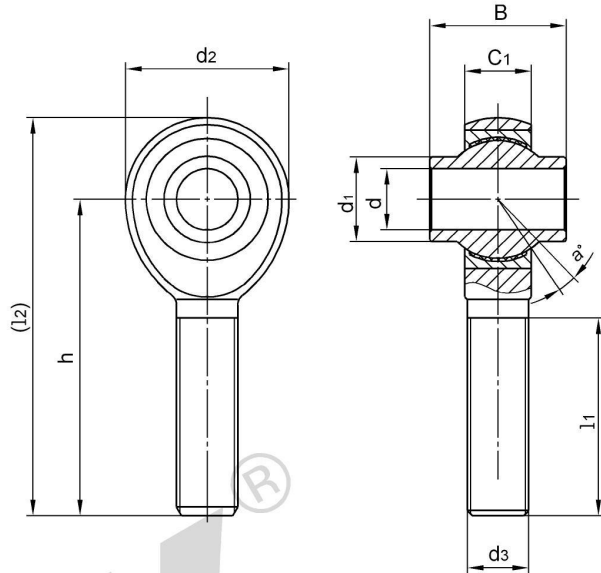

Bearing No.	Dimensions(inches)									Ball dia	a° mis. angle	Load ratings (KN)	weight ≈ kg
	d <sup>+0.0000</sup> <sub>-0.0005</sub>	B <sup>+0.000</sup> <sub>-0.002</sub>	C1 <sup>+0.005</sup> <sub>-0.005</sub>	d2 <sup>+0.010</sup> <sub>-0.010</sub>	d3 <sub>UNF-3A</sub>	h <sup>+0.015</sup> <sub>-0.015</sub>	l1 <sup>+0.031</sup> <sub>-0.031</sub>	(l2)	d1				
HJMX6T	0.3750	0.813	0.355	1.150	3/8-24	2.125	1.281	2.70	0.512	0.781	21	50.6	0.054
HJMX7T	0.4375	0.875	0.355	1.337	7/16-20	2.438	1.468	3.10	0.618	0.875	21	69.9	0.104
HJMX8T	0.5000	0.937	0.411	1.525	1/2-20	2.625	1.562	3.38	0.730	1.000	18	105.4	0.149
HJMX10T	0.6250	1.200	0.577	1.775	5/8-18	2.875	1.678	3.72	0.856	1.250	19	125	0.258
HJMX12T	0.7500	1.280	0.630	2.025	3/4-16	3.375	2.000	4.38	0.970	1.375	17	172.2	0.371

Can supply rod ends with different pitch or accuracy of thread.

For left-hand thread, suffix"L" is added to bearing numbers. eg.: HJMXL6T 3/8-24L

## HRSMX..T

Ball: Gcr15 Steel, heat treated, HRC56min;  
precision ground polished, hard  
chromium plated

Body: 4340 steel, heat treated,  
zinc plated, chromate treated

Race: Steel alloy, zinc plated, chromate treated

Liner: PTFE composite or PTFE fabric

Sliding contact surfaces: Steel/PTFE Composite  
or Steel/PTFE fabric

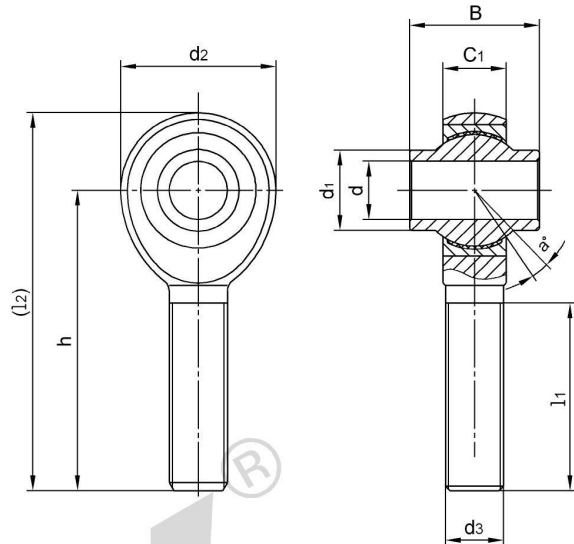

Bearing No.	Dimensions(inches)									Ball dia	a° mis. angle	Load ratings (KN)	weight ≈ kg
	d <sup>+0.038</sup> / <sub>-0.012</sub>	B	C <sub>1</sub>	d <sub>2</sub>	d <sub>3</sub> UNF-2A	h	l <sub>1</sub>	(l <sub>2</sub> )	d <sub>1</sub>				
HRSMX6T	0.3750	0.813	0.355	1.150	3/8-24	2.125	1.281	2.70	0.512	0.781	21	52.4	0.054
HRSMX7T	0.4375	0.875	0.355	1.337	7/16-20	2.438	1.468	3.10	0.618	0.875	21	76	0.104
HRSMX8T	0.5000	0.937	0.411	1.525	1/2-20	2.625	1.562	3.38	0.730	1.000	18	105.4	0.149
HRSMX10T	0.6250	1.200	0.577	1.775	5/8-18	2.875	1.678	3.72	0.856	1.250	19	142.7	0.258
HRSMX12T	0.7500	1.280	0.630	2.025	3/4-16	3.375	2.000	4.38	0.970	1.375	17	172.2	0.371

Can supply rod ends with different pitch or accuracy of thread.

For left-hand thread, suffix"L" is added to bearing numbers. eg.: HRSMXL6T 3/8-24L



**PMX..T**

Ball: 440C Stainless steel, heat treated, HRC56 min,  
precision ground, polished

Body: 4340 steel, heat treated, zinc plated,  
chromate treated

Race: 17-4Ph Stainless steel, heat treated

Liner: PTFE composite or PTFE fabric

Sliding contact surfaces: Steel/PTFE composite  
or Steel/PTFE fabric

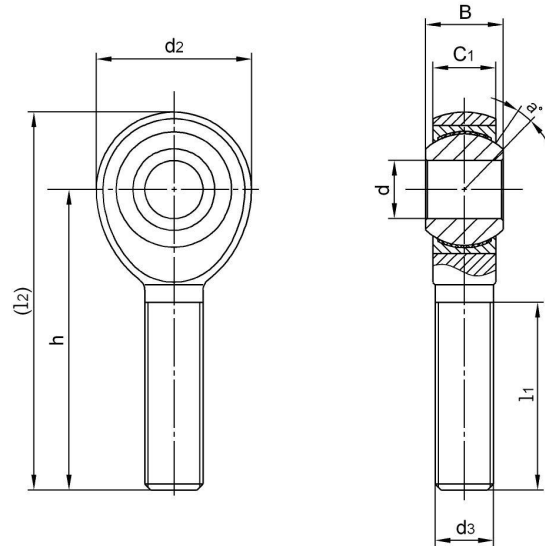

Bearing No.	Dimensions(mm/inches)								Ball dia	a° mis. angle	Load ratings (KN)	weight ≈ kg
	d <sup>+0.038</sup> <sub>-0.012</sub>	B	C <sub>1</sub>	d <sub>2</sub>	d <sub>3</sub> UNF-2A	h	l <sub>1</sub>	(l <sub>2</sub> )				
PMX5T	7.938	11.11	8.31	22.86	5/16-24	47.63	30.15	59.06	15.06	14	36.9	0.039
	0.3125	0.437	0.327	0.900		1.875	1.187	2.325	0.593			
PMX6T	9.525	12.7	10.57	26.03	3/8-24	49.22	30.15	62.23	17.45	12	48.6	0.061
	0.3750	0.500	0.416	1.025		1.938	1.187	2.450	0.687			
PMX7T	11.112	14.27	11.48	29.21	7/16-20	53.98	32.54	68.58	19.83	14	62.5	0.083
	0.4375	0.562	0.452	1.150		2.125	1.281	2.700	0.781			
PMX8T	12.7	15.88	13.8	33.96	1/2-20	61.92	37.29	78.9	22.22	12	103.7	0.126
	0.5000	0.625	0.515	1.337		2.438	1.468	3.106	0.875			
PMX10T	15.875	19.05	14.66	38.74	5/8-18	66.68	39.67	86.05	26.97	16	115.2	0.192
	0.6250	0.750	0.577	1.525		2.625	1.562	3.387	1.062			
PMX12T	19.05	22.23	16.27	45.09	3/4-16	73.03	42.85	95.57	31.75	14	152.6	0.289
	0.7500	0.875	0.640	1.775		2.875	1.687	3.762	1.250			

Can supply rod ends with different pitch or accuracy of thread.

For left-hand thread, suffix"L" is added to bearing numbers. eg.: PMXL12T 3/4-16L



## RSM.. RSM..T

Ball: Gcr15 Steel, heat treated, HRC56min;  
precision ground, polished hard  
chromium plated

Body: carbon steel Zinc plated,chromate treated

Race: Steel alloy, heat treated

zinc plated, chromate treated

Sliding contact surfaces: Steel/Steel or Steel/PTFE composite

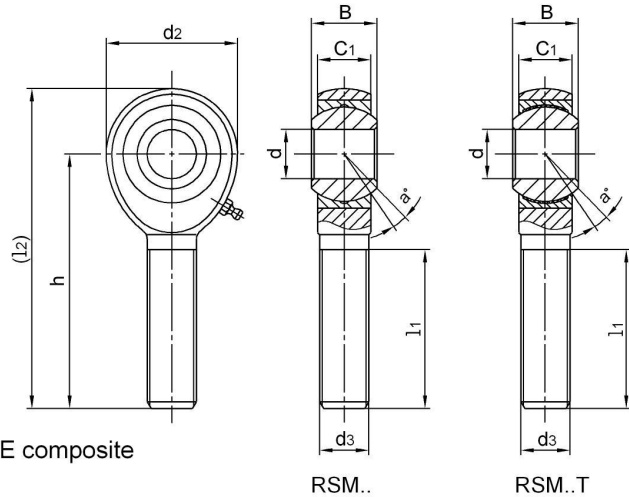

Bearing No.	Dimensions(mm/inches)								Ball dia	a° mis. angle	Load ratings (KN)	weight ≈ kg
	d <sup>+0.038 -0.012</sup>	B	C <sub>1</sub>	d <sub>2</sub>	d <sub>3</sub> UNF-2A	h	l <sub>1</sub>	(l <sub>2</sub> )				
RSM3	4.826	7.92	6.35	19.05	1/4-28	39.67	25.4	49.2	11.11	10	4.4	0.019
RSM3T	0.1900	0.312	0.250	0.750		1.562	1.000	1.938	0.437			
RSM4	6.35	9.53	7.14	22.23	5/16-24	47.63	31.75	58.75	12.7	13	8.2	0.032
RSM4T	0.2500	0.375	0.281	0.875		1.875	1.250	2.312	0.500			
RSM5	7.938	11.10	8.74	25.4	3/8-24	49.22	31.75	61.92	15.88	12	11.1	0.050
RSM5T	0.3125	0.437	0.344	1.000		1.938	1.250	2.437	0.625			
RSM6Z	9.525	12.7	10.31	28.58	7/16-20	53.98	34.93	68.27	18.26	10	13.3	0.072
RSM6T	0.3750	0.500	0.406	1.125		2.125	1.375	2.688	0.719			
RSM7Z	11.112	14.27	11.1	33.32	1/2-20	61.92	38.1	78.58	20.62	12	18.5	0.113
RSM7T	0.4375	0.562	0.437	1.312		2.438	1.500	3.093	0.812			
RSM8Z	12.7	15.88	12.7	38.1	5/8-18	66.68	41.25	85.73	23.8	10	29.1	0.173
RSM8T	0.5000	0.625	0.500	1.500		2.625	1.625	3.375	0.937			
RSM10Z	15.875	19.05	14.27	44.45	3/4-16	73.02	44.45	95.25	28.58	13	31.2	0.273
RSM10T	0.6250	0.750	0.562	1.750		2.875	1.750	3.750	1.125			

Notes:

For grease fittings add " Z" to suffix,example: RSM6Z

For teflon liner add " T" to suffix,example: RSM10T

Can supply rod ends with different pitch or accuracy of thread.

For left-hand thread, suffix"L" is added to bearing numbers. eg.: RSML6 7/16-20L

For RSM3,RSM4,RSM5,zerk grease fitting is not available.



## RSMX.. RSMX..T

Ball: Gcr15 Steel, heat treated, HRC56min;  
 precision ground, polished, hard chromium plated  
 Body: Steel alloy, heat treated, zinc plated,  
 chromate treated  
 Race: Steel alloy, heat treated, zinc plated, chromate treated  
 Liner: PTFE Composite  
 Sliding contact surfaces: Steel/Steel or Steel/PTFE composite

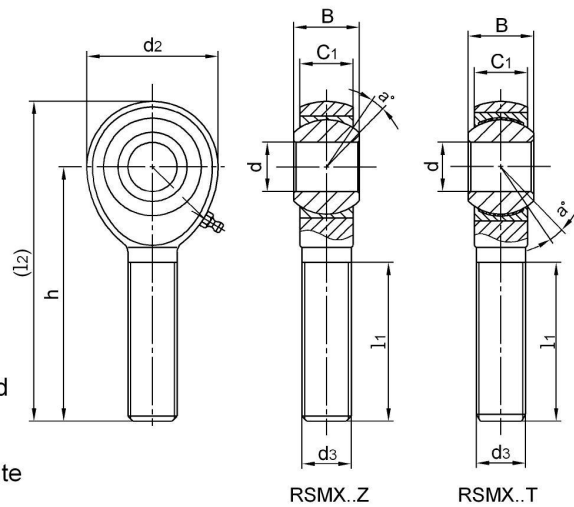

Bearing No.	Dimensions(mm/inches)								Ball dia	a° mis. angle	Load ratings (KN)	weight ≈ kg
	d <sup>+0.038 -0.012</sup>	B	C <sub>1</sub>	d <sub>2</sub>	d <sub>3</sub> UNF-2A	h	l <sub>1</sub>	(l <sub>2</sub> )				
RSMX3	4.826	7.92	6.35	19.05	1/4-28	39.67	25.4	49.2	11.11	10	23.4	0.019
RSMX3T	0.1900	0.312	0.250	0.750		1.562	1.000	1.937	0.437			
RSMX4	6.35	9.53	7.14	22.23	5/16-24	47.63	31.75	58.75	12.7	13	37.6	0.032
RSMX4T	0.2500	0.375	0.281	0.875		1.875	1.250	2.312	0.500			
RSMX5	7.938	11.10	8.74	25.4	3/8-24	49.22	31.75	61.92	15.88	10	57.8	0.050
RSMX5T	0.3125	0.437	0.344	1.000		1.938	1.250	2.437	0.625			
RSMX6Z	9.525	12.7	10.31	28.58	7/16-20	53.98	34.93	68.27	18.26	9	78.3	0.072
RSMX6T	0.3750	0.500	0.406	1.125		2.125	1.375	2.687	0.719			
RSMX7Z	11.112	14.27	11.1	33.32	1/2-20	61.92	38.1	78.58	20.62	11	104.3	0.112
RSMX7T	0.4375	0.562	0.437	1.312		2.438	1.500	3.093	0.812			
RSMX8Z	12.7	15.88	12.7	38.1	5/8-18	66.68	41.28	85.73	23.8	9	139.7	0.173
RSMX8T	0.5000	0.625	0.500	1.500		2.625	1.625	3.375	0.937			
RSMX10Z	15.875	19.05	14.27	44.45	3/4-16	73.03	44.45	95.25	28.58	11	180.5	0.273
RSMX10T	0.6250	0.750	0.562	1.75		2.875	1.750	3.75	1.125			
RSMX12Z	19.05	22.23	17.45	50.8	3/8-14	85.73	47.63	111.1	33.33	10	247.7	0.416
RSMX12T	0.7500	0.875	0.687	2.000		3.375	1.875	4.375	1.312			
RSMX14Z	22.225	22.23	19.43	58.72	1-14	96.52	60.33	125.88	33.33	5	280.6	0.590
RSMX14T	0.8750	0.8750	0.765	2.312		3.8	2.375	4.955	1.312			

### Notes:

- For grease fittings add " Z" to suffix , example: RSMX6Z
- For teflon liner add " T" to suffix , example: RSMX12T
- Can supply rod ends with different pitch or accuracy of thread.
- For RSMX3,RSMX4,RSMX5,zerk grease fitting is not available.

**NXF..**

Ball: Gcr15 Steel, heat treated, HRC56min;  
 precision ground, polished,hard  
 chromium plated

Body: Alloy steel heat treated; zinc plated;

Race: Nylon polymer with PTFE additive

Sliding contact surfaces: Steel/Nylon

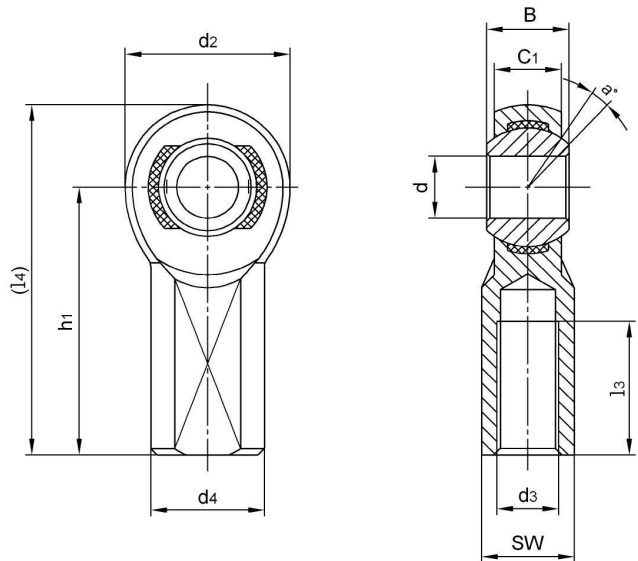

Bearing No.	Dimensions(mm/inches)										Ball dia	a° mis. angle	Load ratings (KN)	weight ≈ kg
	d <sup>+0.038 -0.012</sup>	B	C <sub>1</sub>	d <sub>2</sub>	d <sub>3</sub> UNF-2B	h <sub>1</sub>	l <sub>3</sub>	(l <sub>4</sub> )	d <sub>4</sub>	SW				
NXF3	4.826	7.92	6.35	15.88	10-32	26.97	11.11	34.91	10.31	7.92	11.11	10	16.6	0.018
	0.1900	0.312	0.250	0.625		1.062	0.437	1.375	0.406	0.312	0.437			
NXF4	6.35	9.53	7.14	19.05	1/4-28	33.32	14.27	42.85	11.89	9.52	12.7	13	27.5	0.027
	0.2500	0.375	0.281	0.750		1.312	0.562	1.687	0.468	0.375	0.500			
NXF5	7.938	11.10	8.74	22.23	5/16-24	34.92	15.88	46.03	12.7	11.1	15.88	10	33.9	0.040
	0.3125	0.437	0.344	0.875		1.375	0.625	1.812	0.500	0.437	0.625			
NXF6	9.525	12.7	10.31	25.4	3/8-24	41.28	19.05	53.98	17.45	14.27	18.26	9	42.4	0.063
	0.3750	0.500	0.406	1.000		1.625	0.75	2.125	0.687	0.562	0.719			
NXF7	11.11	14.27	11.1	28.58	7/16-20	46.02	22.22	60.31	19.05	15.88	20.62	11	45.7	0.086
	0.4375	0.562	0.437	1.125		1.812	0.875	2.375	0.750	0.625	0.812			
NXF8	12.7	15.88	12.7	33.32	1/2-20	53.98	25.4	70.64	22.22	19.05	23.8	9	72.2	0.140
	0.5000	0.625	0.500	1.312		2.125	1.000	2.781	0.875	0.750	0.937			
NXF10	15.875	19.05	14.27	38.1	5/8-18	63.5	31.75	82.55	25.4	22.23	28.58	11	79.8	0.204
	0.6250	0.750	0.562	1.500		2.5	1.250	3.250	1.000	0.875	1.125			
NXF12	19.05	22.23	17.45	44.45	3/4-16	73.02	38.1	95.25	28.58	25.4	33.33	10	124.9	0.313
	0.7500	0.875	0.687	1.750		2.875	1.500	3.750	1.125	1.000	1.312			

Can supply rod ends with different pitch or accuracy of thread.

For left-hand thread, suffix"L" is added to bearing numbers. eg.: NXFL12 3/4-16L

**NXM..**

Ball: Gcr15 Steel, heat treated, HRC56min;  
 precision ground, polished, hard  
 chromium plated

Body: Alloy steel heat treated; zinc plated;

Race: Nylon polymer with PTFE additive

Sliding contact surfaces: Steel/Nylon

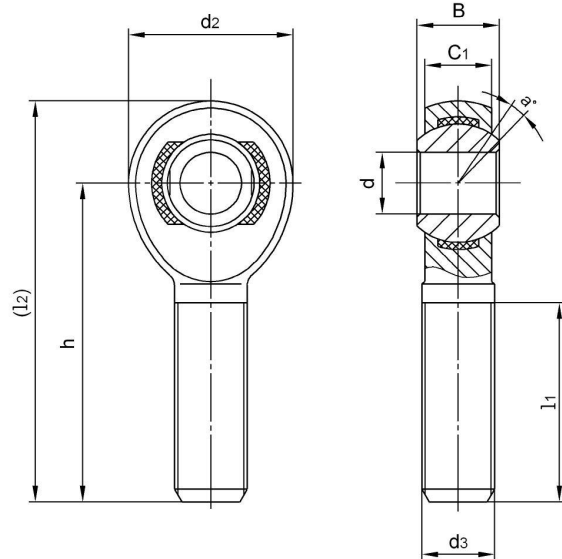

Bearing No.	Dimensions(mm/inches)								Ball dia	a° mis. angle	Load ratings (KN)	weight ≈ g
	d <sup>+0.038</sup> <sub>-0.012</sub>	B	C1	d2	d3 <sub>UNF-2A</sub>	h	l1	(l2)				
NXM3	4.826	7.92	6.35	15.88	10-32	31.75	19.05	39.69	11.11	10	12.6	0.013
	0.1900	0.312	0.250	0.625		1.250	0.750	1.562	0.437			
NXM4	6.35	9.53	7.14	19.05	1/4-28	39.67	25.4	49.2	12.7	13	23.3	0.018
	0.2500	0.375	0.281	0.750		1.562	1.000	1.937	0.500			
NXM5	7.938	11.10	8.74	22.23	5/16-24	47.63	31.75	58.75	15.88	10	33.9	0.031
	0.3125	0.437	0.344	0.875		1.875	1.250	2.312	0.625			
NXM6	9.525	12.7	10.31	25.4	3/8-24	49.22	31.75	61.92	18.26	9	42.4	0.049
	0.3750	0.500	0.406	1.000		1.938	1.250	2.687	0.719			
NXM7	11.112	14.27	11.1	28.58	7/16-20	53.98	34.93	68.27	20.62	11	45.7	0.068
	0.4375	0.562	0.437	1.125		2.125	1.375	2.678	0.812			
NXM8	12.7	15.88	12.7	33.32	1/2-20	61.92	38.1	78.58	23.8	9	72.2	0.108
	0.5000	0.625	0.500	1.312		2.438	1.500	3.093	0.937			
NXM10	15.875	19.05	14.27	38.1	5/8-18	66.68	41.28	85.73	28.58	11	79.8	0.163
	0.6250	0.750	0.562	1.500		2.625	1.625	3.375	1.125			
NXM12	19.05	22.23	17.45	44.45	3/4-16	73.02	44.45	95.25	33.33	10	124.9	0.258
	0.7500	0.875	0.687	1.750		2.875	1.750	3.750	1.312			

Can supply rod ends with different pitch or accuracy of thread.

For left-hand thread, suffix "L" is added to bearing numbers. eg.: NXML12 3/4-16L

**NEXF..**

Ball: Gcr15 Steel, heat treated, HRC56min;  
 precision ground, polished, hard  
 chromium plated

Body: Carbon steel, zinc plated, chromate treated

Race: Nylon polymer with PTFE additive

Sliding contact surfaces: Steel/Nylon

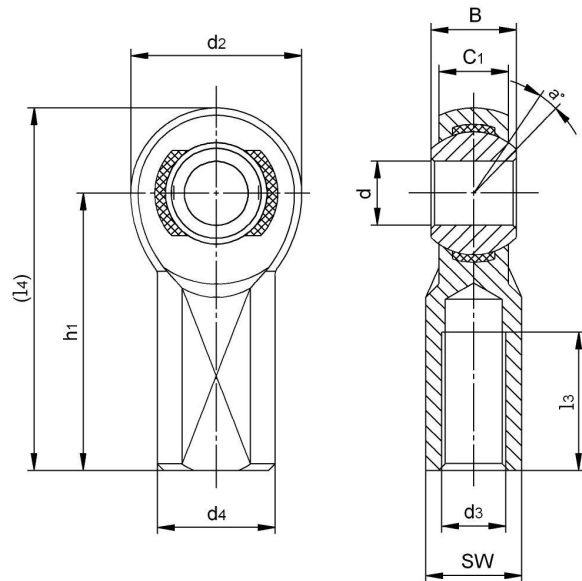

Bearing No.	Dimensions(mm/inches)										Ball dia	a° mis. angle	Load ratings (KN)	weight ≈ kg
	d <sup>+0.038</sup> <sub>-0.012</sub>	B	C1	d2	d3 <sub>UNF-2B</sub>	h1	l3	(l4)	d4	SW				
NEXF3	4.826	7.92	6.35	15.88	10-32	26.97	11.11	34.91	10.31	7.92	11.11	10	6.8	0.018
	0.1900	0.312	0.250	0.625		1.062	0.437	1.375	0.406	0.312	0.437			
NEXF4	6.35	9.53	7.14	19.05	1/4-28	33.32	14.27	42.85	11.89	9.52	12.7	13	11.2	0.027
	0.2500	0.375	0.281	0.750		1.312	0.562	1.687	0.468	0.375	0.500			
NEXF5	7.938	11.10	8.74	22.23	5/16-24	34.92	15.88	46.03	12.7	11.1	15.88	10	13.9	0.040
	0.3125	0.437	0.344	0.875		1.375	0.625	1.812	0.500	0.437	0.625			
NEXF6	9.525	12.7	10.31	25.4	3/8-24	41.28	19.05	53.98	17.45	14.27	18.26	9	17.4	0.063
	0.3750	0.500	0.406	1.000		1.625	0.75	2.125	0.687	0.562	0.719			
NEXF7	11.11	14.27	11.1	28.58	7/16-20	46.02	22.22	60.31	19.05	15.88	20.62	11	18.7	0.086
	0.4375	0.562	0.437	1.125		1.812	0.875	2.375	0.750	0.625	0.812			
NEXF8	12.7	15.88	12.7	33.32	1/2-20	53.98	25.4	70.64	22.22	19.05	23.8	9	29.6	0.140
	0.5000	0.625	0.500	1.312		2.125	1.000	2.781	0.875	0.750	0.937			
NEXF10	15.875	19.05	14.27	38.1	5/8-18	63.5	31.75	82.55	25.4	22.23	28.58	11	32.7	0.204
	0.6250	0.750	0.562	1.500		2.5	1.250	3.250	1.000	0.875	1.125			
NEXF12	19.05	22.23	17.45	44.45	3/4-16	73.02	38.1	95.25	28.58	25.4	33.33	10	51.2	0.313
	0.7500	0.875	0.687	1.750		2.875	1.500	3.750	1.125	1.000	1.312			

Can supply rod ends with different pitch or accuracy of thread.

For left-hand thread, suffix "L" is added to bearing numbers. eg.: NEXFL12 3/4-16L



**NEXM..**

Ball: Gcr15 Steel, heat treated, HRC56min;

precision ground, polished, hard

chromium plated

Body: Carbon steel, zinc plated, chromate treated

Race: Nylon polymer with PTFE additive

Sliding contact surfaces: Steel/Nylon

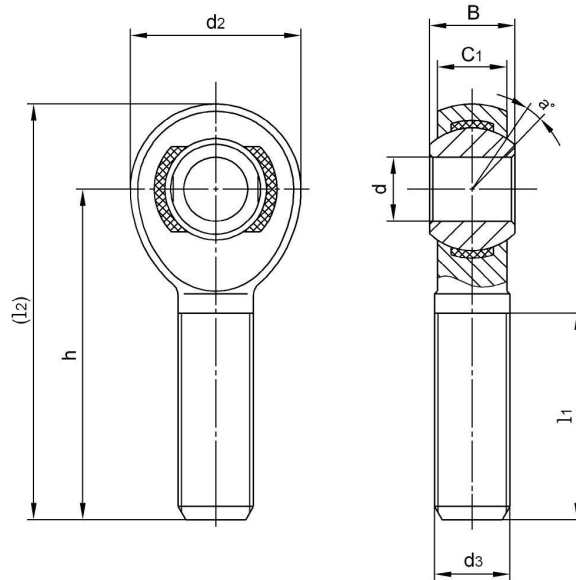

Bearing No.	Dimensions(mm/inches)								Ball dia	a° mis. angle	Load ratings (KN)	weight ≈ kg
	d	B	C <sub>1</sub>	d <sub>2</sub>	d <sub>3</sub> UNF-2A	h	l <sub>1</sub>	(l <sub>2</sub> )				
NEXM3	4.826	7.92	6.35	15.88	10-32	31.75	19.05	39.69	11.11	10	4.4	0.013
	0.1900	0.312	0.250	0.625		1.250	0.750	1.562	0.437			
NEXM4	6.35	9.53	7.14	19.05	1/4-28	39.67	25.4	49.2	12.7	13	8.2	0.018
	0.2500	0.375	0.281	0.750		1.562	1.000	1.937	0.500			
NEXM5	7.938	11.10	8.74	22.23	5/16-24	47.63	31.75	58.75	15.88	10	12.3	0.031
	0.3125	0.437	0.344	0.875		1.875	1.250	2.312	0.625			
NEXM6	9.525	12.7	10.31	25.4	3/8-24	49.22	31.75	61.92	18.26	9	17.4	0.049
	0.3750	0.500	0.406	1.000		1.938	1.250	2.687	0.719			
NEXM7	11.112	14.27	11.1	28.58	7/16-20	53.98	34.93	68.27	20.62	11	18.7	0.068
	0.4375	0.562	0.437	1.125		2.125	1.375	2.678	0.812			
NEXM8	12.7	15.88	12.7	33.32	1/2-20	61.92	38.1	78.58	23.8	9	29.6	0.108
	0.5000	0.625	0.500	1.312		2.438	1.500	3.093	0.937			
NEXM10	15.875	19.05	14.27	38.1	5/8-18	66.68	41.28	85.73	28.58	11	32.7	0.163
	0.6250	0.750	0.562	1.500		2.625	1.625	3.375	1.125			
NEXM12	19.05	22.23	17.45	44.45	3/4-16	73.02	44.45	95.25	33.33	10	51.2	0.258
	0.7500	0.875	0.687	1.750		2.875	1.750	3.750	1.312			

Can supply rod ends with different pitch or accuracy of thread.

For left-hand thread, suffix "L" is added to bearing numbers. eg.: NEXML12 3/4-16L

## NJF..

Ball: Gcr15 Steel, heat treated, HRC56min;  
precision ground, polished, hard  
chromium plated

Body: Carbon steel, zinc plated, chromate treated

Race: PTFE lubricated, fiber reinforced  
Engineering plastic

Sliding contact surfaces: Steel/engineering plastic

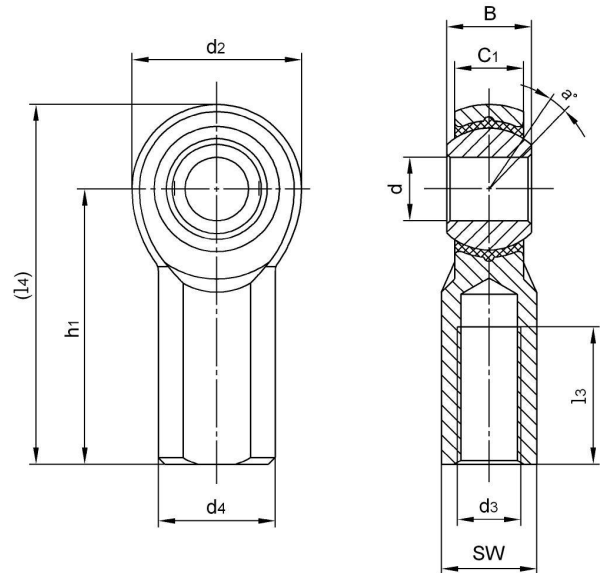

Bearing No.	Dimensions(mm/inches)										Ball dia	a° mis. angle	Load ratings (KN)	weight ≈ kg
	d	B	C1	d2	d3 UNF-2B	h1	l3	(L4)	d4	SW				
NJF3	4.826	7.92	6.35	15.88	10-32	26.97	11.1	34.91	10.31	7.92	11.11	10	5.4	0.018
	0.1900	0.312	0.250	0.625		1.062	0.437	1.375	0.406	0.312	0.437			
NJF4	6.35	9.53	7.14	19.05	1/4-28	33.32	14.27	42.85	11.89	9.52	12.7	13	11.11	0.027
	0.2500	0.375	0.281	0.750		1.312	0.562	1.687	0.468	0.375	0.500			
NJF5	7.938	11.10	8.74	22.23	5/16-24	34.92	15.88	46.03	12.7	11.1	15.88	10	12.2	0.040
	0.3125	0.437	0.344	0.875		1.375	0.625	1.812	0.500	0.437	0.625			
NJF6	9.525	12.7	10.31	25.4	3/8-24	41.28	19.05	53.98	17.45	14.27	18.26	9	17.5	0.068
	0.3750	0.500	0.406	1.000		1.625	0.75	2.125	0.687	0.562	0.719			
NJF7	11.11	14.27	11.1	28.58	7/16-20	46.02	22.22	60.31	19.05	15.88	20.62	11	19.1	0.090
	0.4375	0.562	0.437	1.125		1.812	0.875	2.375	0.750	0.625	0.812			
NJF8	12.7	15.88	12.7	33.32	1/2-20	53.98	25.4	70.64	22.22	19.05	23.8	9	28.7	0.149
	0.5000	0.625	0.500	1.312		2.125	1.000	2.781	0.875	0.750	0.937			
NJF10	15.875	19.05	14.27	38.1	5/8-18	63.5	31.75	82.55	25.4	22.23	28.58	11	32.9	0.217
	0.6250	0.750	0.562	1.500		2.5	1.250	3.250	1.000	0.875	1.125			
NJF12	19.05	22.23	17.45	44.45	3/4-16	73.02	38.1	95.25	28.58	25.4	33.33	10	48.6	0.326
	0.7500	0.875	0.687	1.750		2.875	1.500	3.750	1.125	1.000	1.312			

Notes: For studs add " Y " to suffix , Example: NJF6Y

Can supply rod ends with different pitch or accuracy of thread.

For left-hand thread, suffix"L" is added to bearing numbers. eg.: NJFL12 3/4-16L

**NJM..**

Ball: Gcr15 Steel, heat treated, HRC56min;  
 precision ground, polished hard  
 chromium plated

Body: Carbon steel, zinc plated, chromate treated

Race: PTFE lubricated, fiber reinforced  
 engineering plastic

Sliding contact surfaces: Steel/engineering plastic

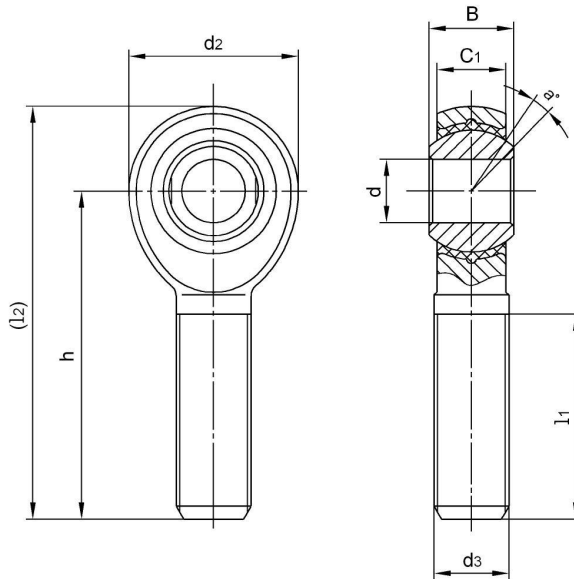

Bearing No.	Dimensions(mm/inches)								Ball dia	a° mis. angle	Load ratings (KN)	weight ≈ kg
	d <sup>+0.038</sup> <sub>-0.012</sub>	B	C <sub>1</sub>	d <sub>2</sub>	d <sub>3</sub> UNF-2A	h	l <sub>1</sub>	(l <sub>2</sub> )				
NJM3	4.826	7.92	6.35	15.88	10-32	31.75	19.05	39.69	11.11	10	4.4	0.013
	0.1900	0.312	0.250	0.625		1.250	0.750	1.562	0.437			
NJM4	6.35	9.53	7.14	19.05	1/4-28	39.67	25.4	49.2	12.7	13	8.2	0.018
	0.2500	0.375	0.281	0.750		1.562	1.000	1.937	0.500			
NJM5	7.938	11.10	8.74	22.23	5/16-24	47.63	31.75	58.75	15.88	10	12.3	0.031
	0.3125	0.437	0.344	0.875		1.875	1.250	2.312	0.625			
NJM6	9.525	12.7	10.31	25.4	3/8-24	49.22	31.75	61.92	18.26	9	17.8	0.049
	0.3750	0.500	0.406	1.000		1.938	1.250	2.687	0.719			
NJM7	11.112	14.27	11.1	28.58	7/16-20	53.98	34.93	68.27	20.62	11	18.8	0.072
	0.4375	0.562	0.437	1.125		2.125	1.375	2.678	0.812			
NJM8	12.7	15.88	12.7	33.32	1/2-20	61.92	38.1	78.58	23.8	9	28.7	0.113
	0.5000	0.625	0.500	1.312		2.438	1.500	3.093	0.937			
NJM10	15.875	19.05	14.27	38.1	5/8-18	66.68	41.28	85.73	28.58	11	32.9	0.172
	0.6250	0.750	0.562	1.500		2.625	1.625	3.375	1.125			
NJM12	19.05	22.23	17.45	44.45	3/4-16	73.02	44.45	95.25	33.33	10	48.6	0.272
	0.7500	0.875	0.687	1.750		2.875	1.750	3.750	1.312			

Notes: For studs add " Y " to suffix , Example: NJM6Y

Can supply rod ends with different pitch or accuracy of thread.

For left-hand thread, suffix"L" is added to bearing numbers. eg.: NJML12 3/4-16L



**NAF..**

Ball: Gcr15 Steel, heat treated, HRC56min;  
 Precision ground, polished, hard  
 chromium plated

Body: Aluminum 6061-T6, hard anodized red

Race: Nylon polymer PTFE additive

Sliding contact surfaces: Steel/Nylon

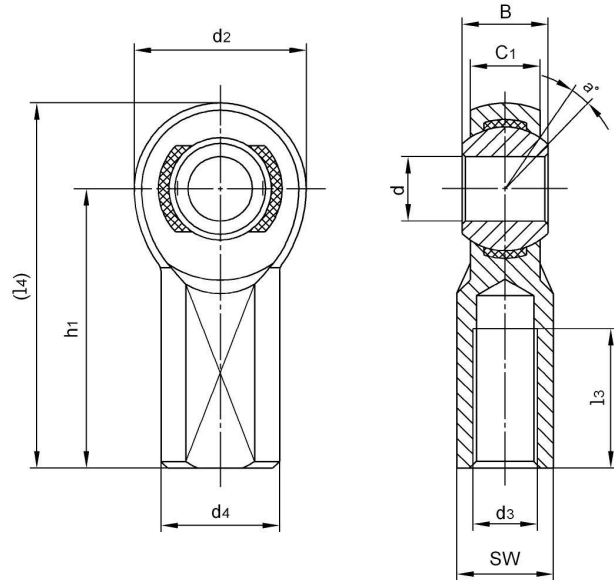

Bearing No.	Dimensions(mm/inches)										Ball dia	a° mis. angle	Load ratings (KN)	weight ≈ g
	d	B	C <sub>1</sub>	d <sub>2</sub>	d <sub>3</sub> UNF-2B	h <sub>1</sub>	l <sub>3</sub>	(L <sub>4</sub> )	d <sub>4</sub>	SW				
NAF3	4.826	7.92	6.35	15.88	10-32	26.97	11.1	34.91	10.31	7.92	11.11	10	6.8	18
	0.1900	0.312	0.250	0.625		1.062	0.437	1.375	0.406	0.312	0.437			
NAF4	6.35	9.53	7.14	19.05	1/4-28	33.32	14.27	42.85	11.89	9.52	12.7	13	11.2	27
	0.2500	0.375	0.281	0.750		1.312	0.562	1.687	0.468	0.375	0.500			
NAF5	7.938	11.10	8.74	22.23	5/16-24	34.92	15.88	46.03	12.7	11.1	15.88	10	13.9	40.8
	0.3125	0.437	0.344	0.875		1.375	0.625	1.812	0.500	0.437	0.625			
NAF6	9.525	12.7	10.31	25.4	3/8-24	41.28	19.05	53.98	17.45	14.27	18.26	9	17.4	63
	0.3750	0.500	0.406	1.000		1.625	0.75	2.125	0.687	0.562	0.719			
NAF7	11.11	14.27	11.1	28.58	7/16-20	46.02	22.22	60.31	19.05	15.88	20.62	11	18.7	86.2
	0.4375	0.562	0.437	1.125		1.812	0.875	2.375	0.750	0.625	0.812			
NAF8	12.7	15.88	12.7	33.32	1/2-20	53.98	25.4	70.64	22.22	19.05	23.8	9	29.6	140.6
	0.500	0.625	0.500	1.312		2.125	1.000	2.781	0.875	0.750	0.937			
NAF10	15.875	19.05	14.27	38.1	5/8-18	63.5	31.75	82.55	25.4	22.23	28.58	11	32.7	204
	0.6250	0.750	0.562	1.500		2.5	1.250	3.250	1.000	0.875	1.125			
NAF12	19.05	22.23	17.45	44.45	3/4-16	73.02	38.1	95.25	28.58	25.4	33.33	10	51.2	313
	0.7500	0.875	0.687	1.750		2.875	1.500	3.750	1.125	1.000	1.312			

Can supply rod ends with different pitch or accuracy of thread.

Aluminum 7075-T6 is available upon request.

For left-hand thread, suffix"L" is added to bearing numbers. eg.: NAF12L 3/4-16L



**NAM..**

Ball: Gcr15 Steel, heat treated, HRC56min;  
 Precision ground, polished hard  
 chromium plated

Body: Aluminum 6061-T6, hard anodized red

Race: Nylon polymer PTFE additive

Sliding contact surfaces: Steel/Nylon

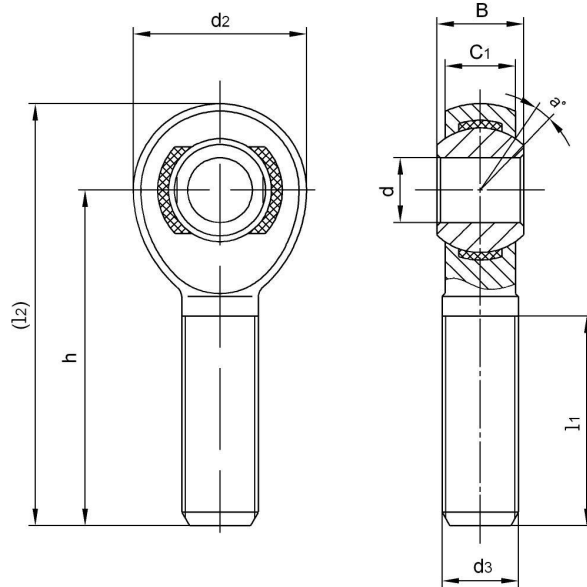

Bearing No.	Dimensions(mm/inches)								Ball dia	a° mis. angle	Load ratings (KN)	weight ≈ g
	d <sup>+0.038</sup> <sub>-0.012</sub>	B	C <sub>1</sub>	d <sub>2</sub>	d <sub>3</sub> UNF-2A	h	l <sub>1</sub>	(l <sub>2</sub> )				
NAM3	4.826	7.92	6.35	15.88	10-32	31.75	19.05	39.69	11.11	10	5.1	13.6
	0.1900	0.312	0.250	0.625		1.250	0.750	1.562	0.437			
NAM4	6.35	9.53	7.14	19.05	1/4-28	39.67	25.4	49.2	12.7	13	9.5	18
	0.2500	0.375	0.281	0.750		1.562	1.000	1.937	0.500			
NAM5	7.938	11.10	8.74	22.23	5/16-24	47.63	31.75	58.75	15.88	10	12.3	31.7
	0.3125	0.437	0.344	0.875		1.875	1.250	2.312	0.625			
NAM6	9.525	12.7	10.31	25.4	3/8-24	49.22	31.75	61.93	18.26	9	17.4	49.8
	0.3750	0.500	0.406	1.000		1.938	1.250	2.438	0.719			
NAM7	11.112	14.27	11.1	28.58	7/16-20	53.98	34.93	68.27	20.62	11	18.7	68
	0.4375	0.562	0.437	1.125		2.125	1.375	2.678	0.812			
NAM8	12.7	15.88	12.7	33.32	1/2-20	61.93	38.1	78.58	23.8	9	29.6	108.8
	0.5000	0.625	0.500	1.312		2.438	1.500	3.093	0.937			
NAM10	15.875	19.05	14.27	38.1	5/8-18	66.68	41.28	85.73	28.58	11	32.7	163.3
	0.6250	0.750	0.562	1.500		2.625	1.625	3.375	1.125			
NAM12	19.05	22.23	17.45	44.45	3/4-16	73.02	44.45	95.25	33.33	10	51.2	258.5
	0.7500	0.875	0.687	1.750		2.875	1.750	3.750	1.312			

Can supply rod ends with different pitch or accuracy of thread.

Aluminum 7075-T6 is available upon request.

For left-hand thread, suffix"L" is added to bearing numbers. eg.: NAML6 3/4-16L

## ALJF..

Ball: Gcr15 Steel, heat treated, HRC56min;  
 precision ground, polished, hard  
 chromium plated

Body: Aluminum 6061-T6, hard anodized red

Race: Steel alloy, heat treated, zinc plated, chromate treated

Sliding contact surfaces: Steel/Steel

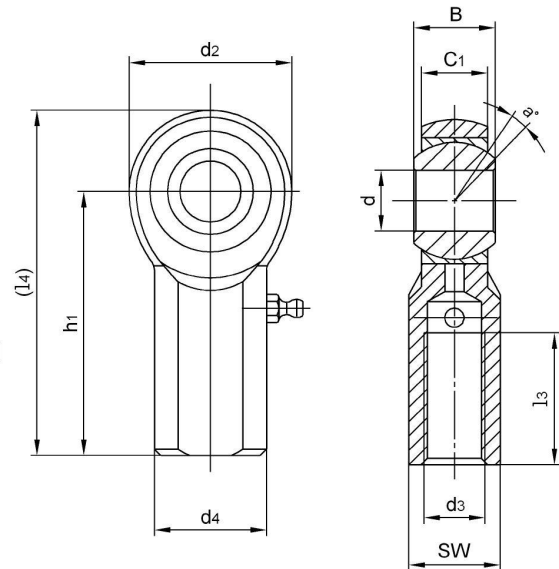

Bearing No.	Dimensions(mm/inches)										Ball dia	a° mis. angle	Load ratings (KN)	weight ≈ kg
	d <sup>+0.038 -0.012</sup>	B	C <sub>1</sub>	d <sub>2</sub>	d <sub>3</sub> UNF-2B	h <sub>1</sub>	l <sub>3</sub>	(14)	d <sub>4</sub>	SW				
ALJF3	4.826	7.92	6.35	15.88	10-32	26.97	11.1	34.91	10.31	7.92	11.11	10	4.4	0.018
	0.1900	0.312	0.250	0.625		1.062	0.437	1.375	0.406	0.312	7/16			
ALJF4	6.35	9.53	7.14	19.05	1/4-28	33.32	14.27	42.85	11.89	9.52	12.7	13	7.4	0.027
	0.2500	0.375	0.281	0.750		1.312	0.562	1.687	0.468	0.375	1/2			
ALJF5	7.938	11.10	8.74	22.23	5/16-24	34.92	15.88	46.03	12.7	11.1	15.88	10	9.1	0.040
	0.3125	0.437	0.344	0.875		1.375	0.625	1.812	0.500	0.437	5/8			
ALJF6	9.525	12.7	10.31	25.4	3/8-24	41.28	19.05	53.98	17.45	14.27	18.26	9	10.9	0.068
	0.3750	0.500	0.406	1.000		1.625	0.75	2.125	0.687	0.562	23/32			
ALJF7	11.11	14.27	11.1	28.58	7/16-20	46.02	22.22	60.31	19.05	15.88	20.62	11	15.1	0.090
	0.4375	0.562	0.437	1.125		1.812	0.875	2.375	0.750	0.625	13/16			
ALJF8	12.7	15.88	12.7	33.32	1/2-20	53.98	25.4	70.64	22.22	19.05	23.8	9	23.8	0.149
	0.500	0.625	0.500	1.312		2.125	1.000	2.781	0.875	0.750	15/16			

Notes: For grease fittings add " Z" to suffix. Example: ALJF6Z  
 For studs add " Y" to suffix. Example: ALJF5Y  
 For teflon liner add " T" to suffix. Example: ALJF8T

Can supply rod ends with different pitch or accuracy of thread.

For left-hand thread, suffix " L" is added to bearing numbers. eg.: ALJFL6 3/8-24L



**ALJM..**

Ball: Gcr15 Steel, heat treated, HRC56min;  
 precision ground, polished, hard  
 chromium plated

Body: Aluminum 6061-T6, hard anodized red

Race: Steel alloy, heat treated, zinc plated,  
 chromate treated

Sliding contact surfaces: Steel/Steel

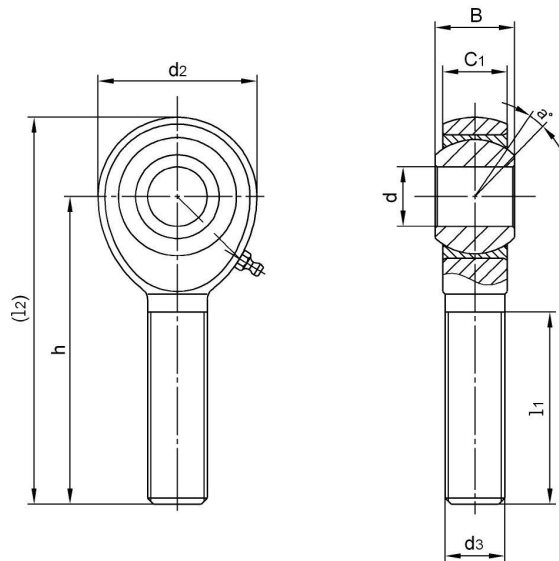

Bearing No.	Dimensions(mm/inches)								Ball dia	a° mis. angle	Load ratings (KN)	weight ≈ kg
	d <sup>+0.038 -0.012</sup>	B	C1	d2	d3 UNF-2A	h	l1	(l2)				
ALJM3	4.826	7.92	6.35	15.88	10-32	31.75	19.05	39.69	11.11	10	3.6	0.009
	0.1900	0.312	0.250	0.625		1.250	0.750	1.562	0.437			
ALJM4	6.35	9.53	7.14	19.05	1/4-28	39.67	25.4	49.2	12.7	13	6.7	0.015
	0.2500	0.375	0.281	0.750		1.562	1.000	1.937	0.500			
ALJM5	7.938	11.10	8.74	22.23	5/16-24	47.63	31.75	58.75	15.88	10	9.1	0.022
	0.3125	0.437	0.344	0.875		1.875	1.250	2.312	0.625			
ALJM6	9.525	12.7	10.31	25.4	3/8-24	49.22	31.75	61.92	18.26	9	10.9	0.035
	0.3750	0.500	0.406	1.000		1.938	1.250	2.687	0.719			
ALJM7	11.112	14.27	11.1	28.58	7/16-20	53.98	34.93	68.27	20.62	11	15.1	0.041
	0.4375	0.562	0.437	1.125		2.125	1.375	2.678	0.812			
ALJM8	12.7	15.88	12.7	33.32	1/2-20	61.92	38.1	78.58	23.8	9	23.8	0.063
	0.5000	0.625	0.500	1.312		2.438	1.500	3.093	0.937			
ALJM8H	12.7	15.88	12.7	33.32	1/2-20	61.92	38.1	78.58	23.8	9	28.7	
	0.5000	0.625	0.500	1.312		2.438	1.500	3.093	0.937			
ALJM10	15.875	19.05	14.27	38.1	5/8-18	66.68	41.28	85.73	28.58	11	25.5	0.108
	0.6250	0.750	0.562	1.500		2.625	1.625	3.375	1.125			
ALJM10H	15.875	19.05	14.27	44.45	5/8-18	66.68	41.28	85.73	28.58	11	33.6	0.121
	0.6250	0.750	0.562	1.750		2.625	1.625	3.375	1.125			
ALJM12	19.05	22.23	17.45	44.45	3/4-16	73.02	44.45	95.25	33.33	10	69.5	0.136
	0.7500	0.875	0.687	1.750		2.875	1.750	3.750	1.312			
ALJM12H	19.05	22.23	17.45	50.8	3/4-16	73.02	44.45	95.25	33.33	10	91.6	0.136
	0.7500	0.875	0.687	2.000		2.875	1.750	3.750	1.312			

Notes: For grease fittings add "Z" to suffix. Example: ALJM6Z  
 For studs add "Y" to suffix. Example: ALJM5Y  
 For teflon liner add "T" to suffix. Example: ALJM8T

Can supply rod ends with different pitch or accuracy of thread.

For left-hand thread, suffix "L" is added to bearing numbers. eg.: ALJML6 3/8-24L

## ALRSM..

Ball: Gcr15 Steel, heat treated, HRC56min;  
 precision ground, polished, hard  
 chromium plated

Body: Aluminum 6061-T6, hard anodized red

Race: Steel alloy, heat treated, zinc plated,  
 chromate treated

Sliding contact surfaces: Steel/Steel

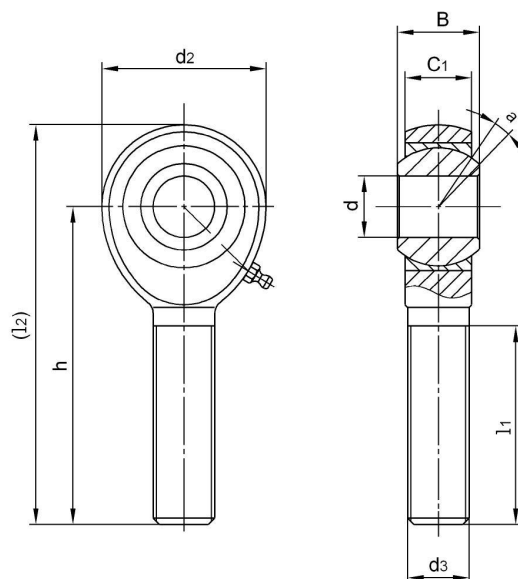

Bearing No.	Dimensions(mm/inches)								Ball dia	a° mis. angle	Load ratings (KN)	weight ≈ kg
	d <sup>+0.038</sup> / <sub>-0.012</sub>	B	C <sub>1</sub>	d <sub>2</sub>	d <sub>3</sub> UNF-2A	h	l <sub>1</sub>	(l <sub>2</sub> )				
ALRSM6	9.525	12.7	10.31	28.58	7/16-20	53.98	34.93	68.27	18.26	14	34.3	0.033
	0.3750	0.500	0.406	1.125		2.125	1.375	2.678	0.719			
ALRSM7	11.112	14.27	11.1	33.32	1/2-20	61.92	38.1	78.58	20.62	12	48.9	0.054
	0.4375	0.562	0.437	1.312		2.438	1.500	3.093	0.812			
ALRSM8	12.7	15.88	12.7	38.1	5/8-18	66.68	41.28	85.73	23.8	12	66.1	0.090
	0.5000	0.625	0.500	1.500		2.625	1.625	3.375	0.937			
ALRSM10	15.875	19.05	14.27	44.45	3/4-16	73.02	44.45	95.25	28.58	16	85.5	0.143
	0.6250	0.750	0.562	1.750		2.875	1.750	3.750	1.125			
ALRSM10-8	12.7	19.05	14.27	44.45	3/4-16	73.02	44.45	95.25	28.58	16	85.5	0.143
	0.500	0.750	0.562	1.750		2.875	1.750	3.750	1.125			

Notes: For grease fittings add " Z" to suffix. Example: ALRSM6Z

For teflon liner add "T" to suffix. Example: ALRSM8T

Can supply rod ends with different pitch or accuracy of thread.

For left-hand thread, suffix "L" is added to bearing numbers. eg.: ALRSM L6 7/16-20L

