

SI..E & SI..ES

Body: Carbon steel Zinc plated, chromate treated

SI..E: Mounted with GE..E type of radial spherical plain bearings.

SI..ES: Mounted with GE..ES type of radial spherical plain bearings.

Sliding contact surfaces: Steel/Steel

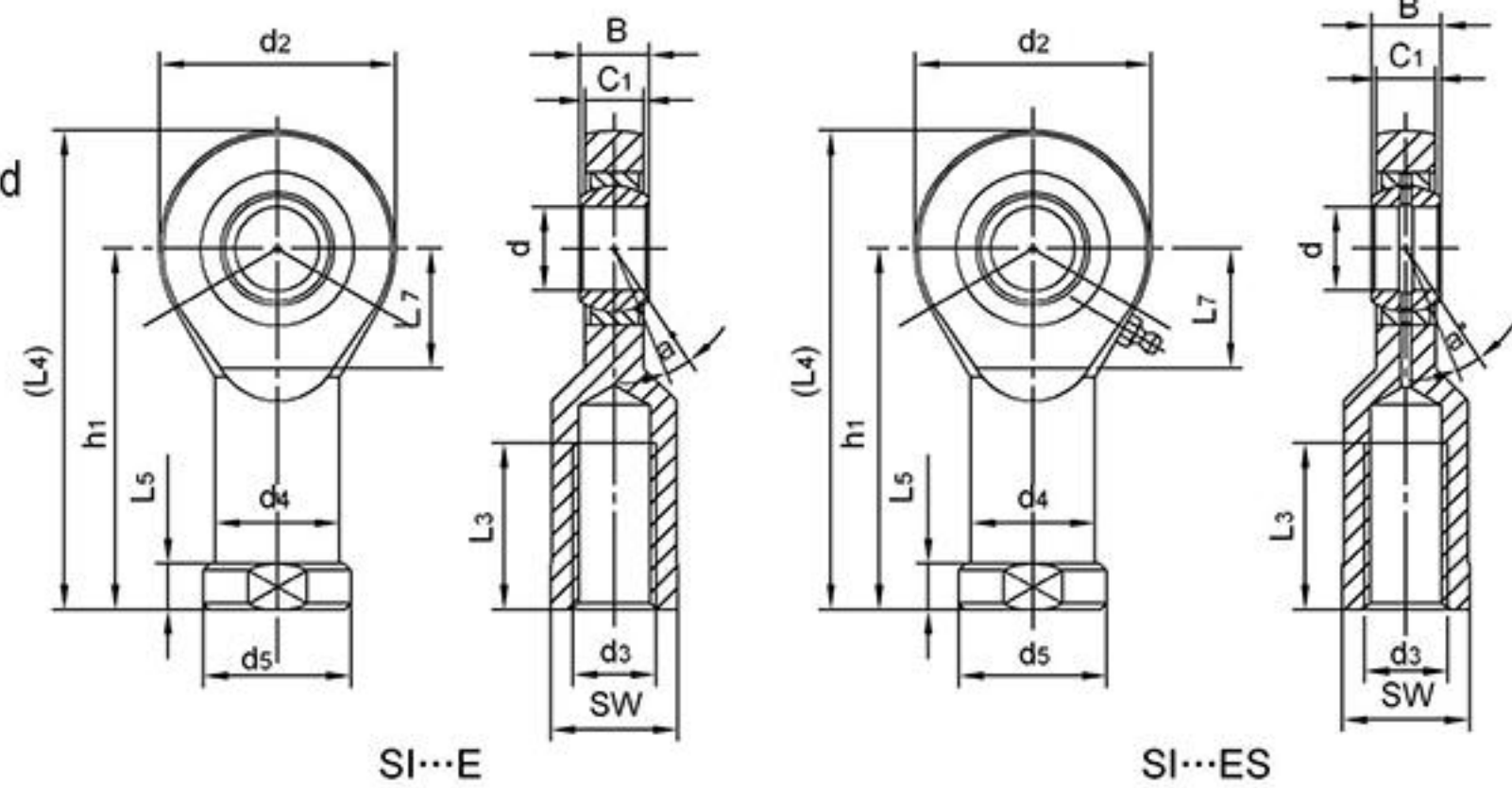

Bearing No.	Dimensions(mm)													Ball dia	a° mis. angle	Load ratings (KN)		Weight ≈ kg
	d	B	C ₁	d ₂	d _{3-6H}	h ₁	L ₃	L ₄	L ₅	L ₇	d ₄	d ₅	W			Dynamic	Static	
SI5E ¹⁾	5	6	4.5	21	M5	30	11	40.5	5	11.5	11	13	11	10	13	3.4	8.1	0.021
SI6E ¹⁾	6	6	4.5	21	M6	30	11	40.5	5	11.5	11	13	11	10	13	3.4	8.1	0.021
SI8E ¹⁾	8	8	6.5	24	M8	36	15	48	5	13	13	16	13	13	15	5.5	12.9	0.039
SI10E ¹⁾	10	9	7.5	29	M10	43	20	57.5	6.5	15	16	19	16	16	12	8.1	17.6	0.061
SI12E ¹⁾	12	10	8.5	34	M12	50	22	67	7	18	18	22	19	18	10	10	24.5	0.096
SI15ES	15	12	10.5	40	M14	61	30	81	8	21	21	26	21	22	8	16	36	0.162
SI17ES	17	14	11.5	46	M16	67	32	90	10	23	25	29	27	25	10	21	45	0.233
SI20ES	20	16	13.5	53	M20x1.5	77	38	103.5	10	25.5	28	34	30	29	9	30	60	0.324
SI25ES	25	20	18	64	M24x2	94	45	126	12	33	35	42	36	35.5	7	48	83	0.625
SI30ES	30	22	20	73	M30x2	110	54	146.5	15	37.5	42	50	46	40.7	6	62	110	0.976
SI35ES	35	25	22	82	M36x3	125	60	166	15	40	48	58	55	47	6	79	146	1.52
SI40ES	40	28	24	92	M39x3	142	65	188	18	47	52	65	60	53	7	99	180	2.06
SI45ES	45	32	28	102	M42x3	145	65	196	20	52	58	70	65	60	7	127	240	2.72
SI50ES	50	35	31	112	M45x3	160	68	216	20	57	62	75	70	66	6	156	290	3.57
SI60ES	60	44	39	135	M52x3	175	70	242.5	20	68.5	70	88	80	80	6	245	450	5.63
SI70ES	70	49	43	160	M56x4	200	80	280	20	81	80	98	85	92	6	313	610	8.33
SI80ES	80	55	48	180	M64x4	230	85	320	25	91	95	110	95	105	6	400	750	13.04

¹⁾Can not be relubricated.

Can supply rod ends with different pitch or accuracy of thread.

For left-hand thread, suffix"L" is added to bearing numbers. eg.: SIL20ES M20 x 1.5L-6H: