

PHSB..

Ball: Gcr15 Steel, heat treated, HRC56min;
 precision ground, polished, hard
 chromium plated

Body: Carbon steel, zinc plated,chromate treated

Race: Brass

Sliding contact surfaces: Steel/Brass

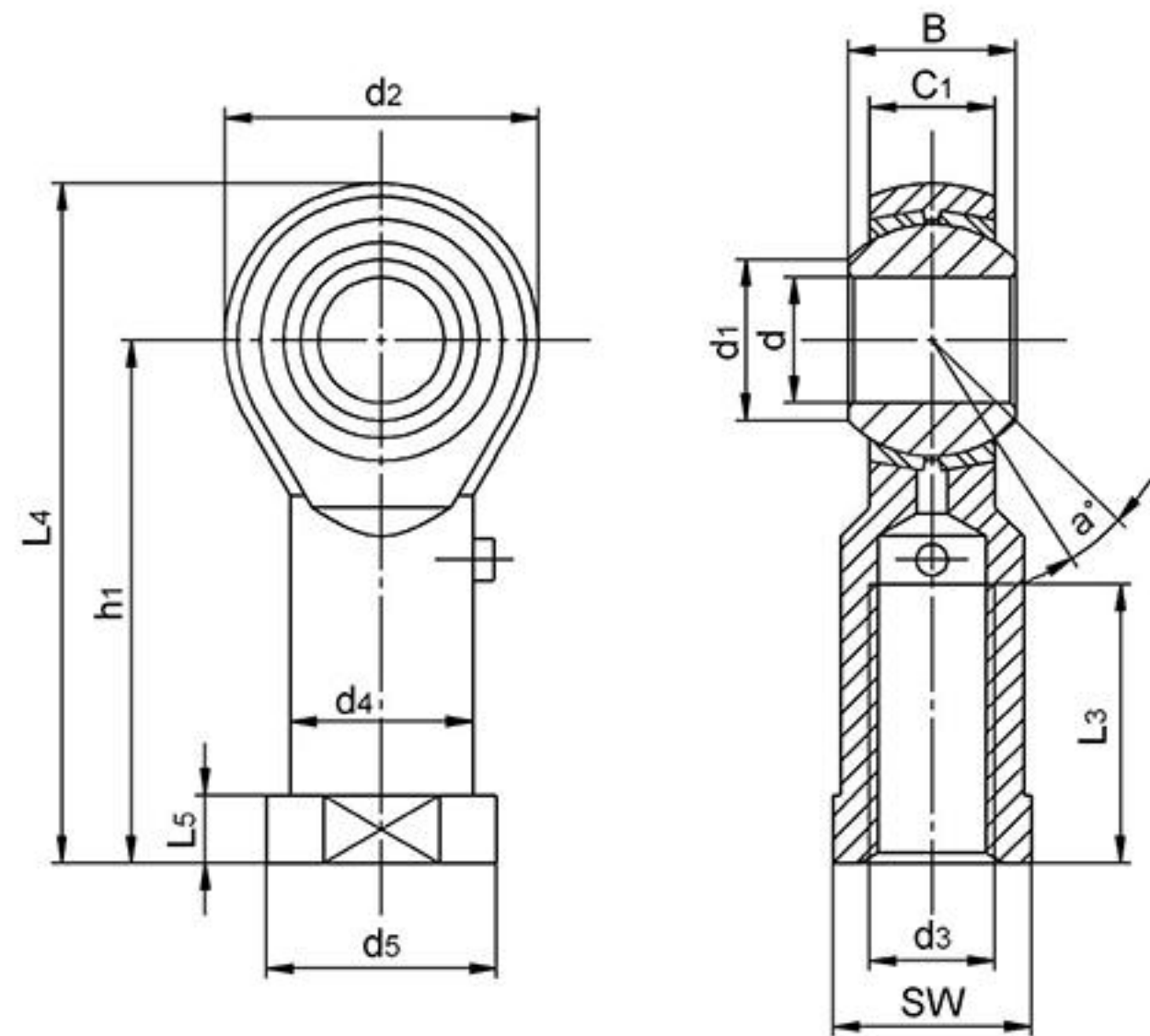

Bearing No.	Dimensions(mm)													Ball dia	a° mis. angle	Load ratings (KN)		weight ≈ kg
	d ^{+0.038} _{-0.012}	B	C1	d1	d2	d3 UNF-2B	h1	L3	(L4)	L5	d4	d5	SW			Dynamic Cr	Static Cor	
PHSB3	4.826	7.92	6.35	7.77	15.88	10-32	26.97	12.7	34.91	4.75	7.92	10.31	7.92	11.11	10	2.8	7.4	0.015
PHSB4	6.35	9.53	7.14	9.02	19.05	1/4-28	33.32	17.45	42.85	4.75	9.52	11.89	9.53	12.7	13	4.8	11.2	0.025
PHSB5	7.938	11.10	8.74	11.35	22.23	5/16-24	34.93	17.45	46.03	4.75	11.1	12.7	11.1	15.87	10	5.9	13.8	0.036
PHSB6	9.525	12.7	10.31	13.13	25.4	3/8-24	41.28	20.62	53.98	6.35	14.27	17.45	14.27	18.26	9	8.2	18.2	0.061
PHSB7	11.112	14.27	11.1	14.88	28.58	7/16-20	46.02	23.8	60.3	6.35	15.88	19.05	15.88	20.62	11	10	22	0.081
PHSB8	12.7	15.88	12.7	17.73	33.32	1/2-20	53.98	26.97	70.64	6.35	19.05	22.22	19.05	23.8	9	15	31.7	0.133
PHSB10	15.875	19.05	14.27	21.31	38.1	5/8-18	63.5	34.92	82.55	7.92	22.22	25.4	22.22	28.57	11	18	35.1	0.190
PHSB12	19.05	22.23	17.45	24.84	44.45	3/4-16	73.03	39.67	95.25	7.92	25.4	28.58	25.4	33.33	10	27	49.6	0.285
PHSB16	25.4	34.93	25.4	32.23	69.85	5/4-12	104.78	53.98	139.7	11.1	38.1	44.45	38.1	47.62	14	60	101	1.000

Can supply rod ends with different pitch or accuracy of thread.

For left-hand thread, suffix "L" is added to bearing numbers. eg.: PHSB12L 3/4-16L