

## SPHSB..EC

Ball: 440C Stainless steel, heat treated  
 HRC56 min, precision ground, polished  
 Body: 304 Stainless steel  
 Race: PTFE composite  
 Sliding contact surfaces: Steel/PTFE composite

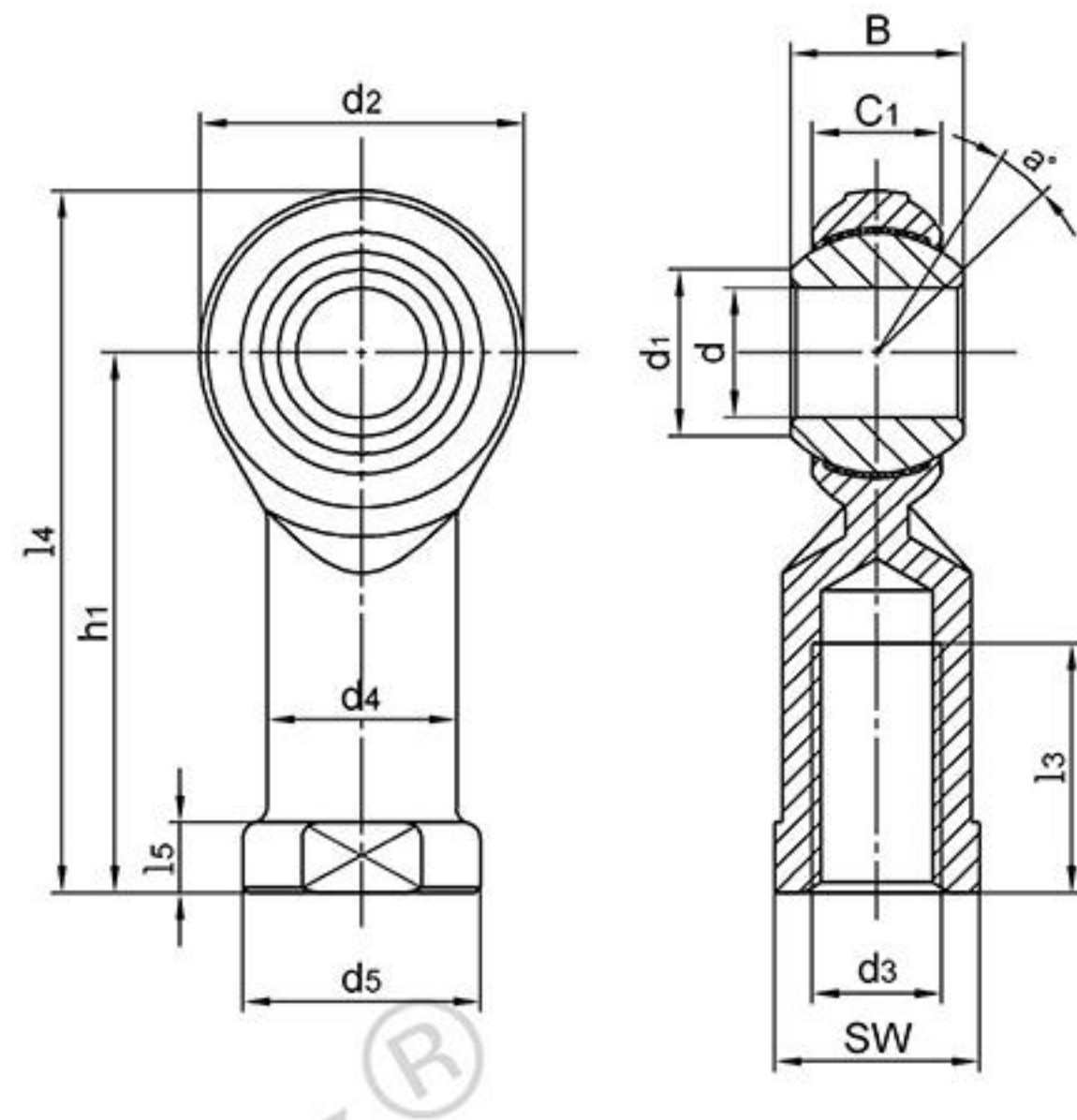

Bearing No.	Dimensions(mm)													Ball dia	a° mis. angle	Load ratings		weight ≈ kg
	d <sup>+0.038</sup> <sub>-0.012</sub>	B	C <sub>1</sub>	d <sub>1</sub>	d <sub>2</sub>	d <sub>3</sub> UNF-2B	h <sub>1</sub>	l <sub>3</sub>	(l <sub>4</sub> )	L <sub>5</sub>	d <sub>4</sub>	d <sub>5</sub>	SW			Dynamic Cr	Static Cor	
SPHSB3EC	4.826	7.92	6.35	7.77	15.88	10-32	26.97	12.7	34.91	4.75	7.92	10.31	7.92	11.11	10	3.3	6.6	0.015
SPHSB4EC	6.35	9.53	7.14	9.02	19.05	1/4-28	33.32	17.45	42.85	4.75	9.52	11.89	9.52	12.7	13	4.8	11	0.025
SPHSB5EC	7.938	11.10	8.74	11.35	22.23	5/16-24	34.92	17.45	46.03	4.75	11.1	12.7	11.1	15.87	10	5.9	12	0.036
SPHSB6EC	9.525	12.7	10.31	13.13	25.4	3/8-24	41.28	20.62	53.98	6.35	14.27	17.45	14.27	18.26	9	8.2	18.2	0.061
SPHSB7EC	11.11	14.27	11.1	14.88	28.58	7/16-20	46.02	23.8	60.3	6.35	15.88	19.05	15.88	20.62	11	10	21.5	0.081
SPHSB8EC	12.7	15.88	12.7	17.73	33.32	1/2-20	53.98	26.97	70.64	6.35	19.05	22.22	19.05	23.8	9	15	30.6	0.133
SPHSB10EC	15.88	19.05	14.27	21.31	38.1	5/8-18	63.5	34.92	82.55	7.92	22.22	25.4	22.22	28.57	11	18	34.1	0.190
SPHSB12EC	19.05	22.23	17.45	24.84	44.45	3/4-16	73.03	39.67	95.25	7.92	25.4	28.58	25.4	33.33	10	27	47.9	0.285

Can supply rod ends with different pitch or accuracy of thread.

For left-hand thread, suffix "L" is added to bearing numbers. eg.: SPHSB12ECL 3/4-16L

