

CS..

CS Ball joint metric size

Material:

Body: low carbon steel.

Ball stud: carbon steel, ball is induction hardened

Inner retaining ring and safety clip: Hard drawn spring steel

Protective Finish:

Ball joint components zinc plated and clear passivated, ball stud, inner retaining ring and safety clip are de-embrittled,

Features

Ball stud is retained by a captive internal wire ring.

Additional stud retention security is provided by the external wire safety clip.

For improved wear resistance, the ball is induction hardened,

Optional polychloroprene gaiter available to help resist dirt ingress.

If a fitted gaiter is required, please add G to the part number e.g. CSG 8/1.

Hexagon form on body.

Spanner flats are not available on CS 12/1 and 16/1.

Burnished ball for smoother operation.

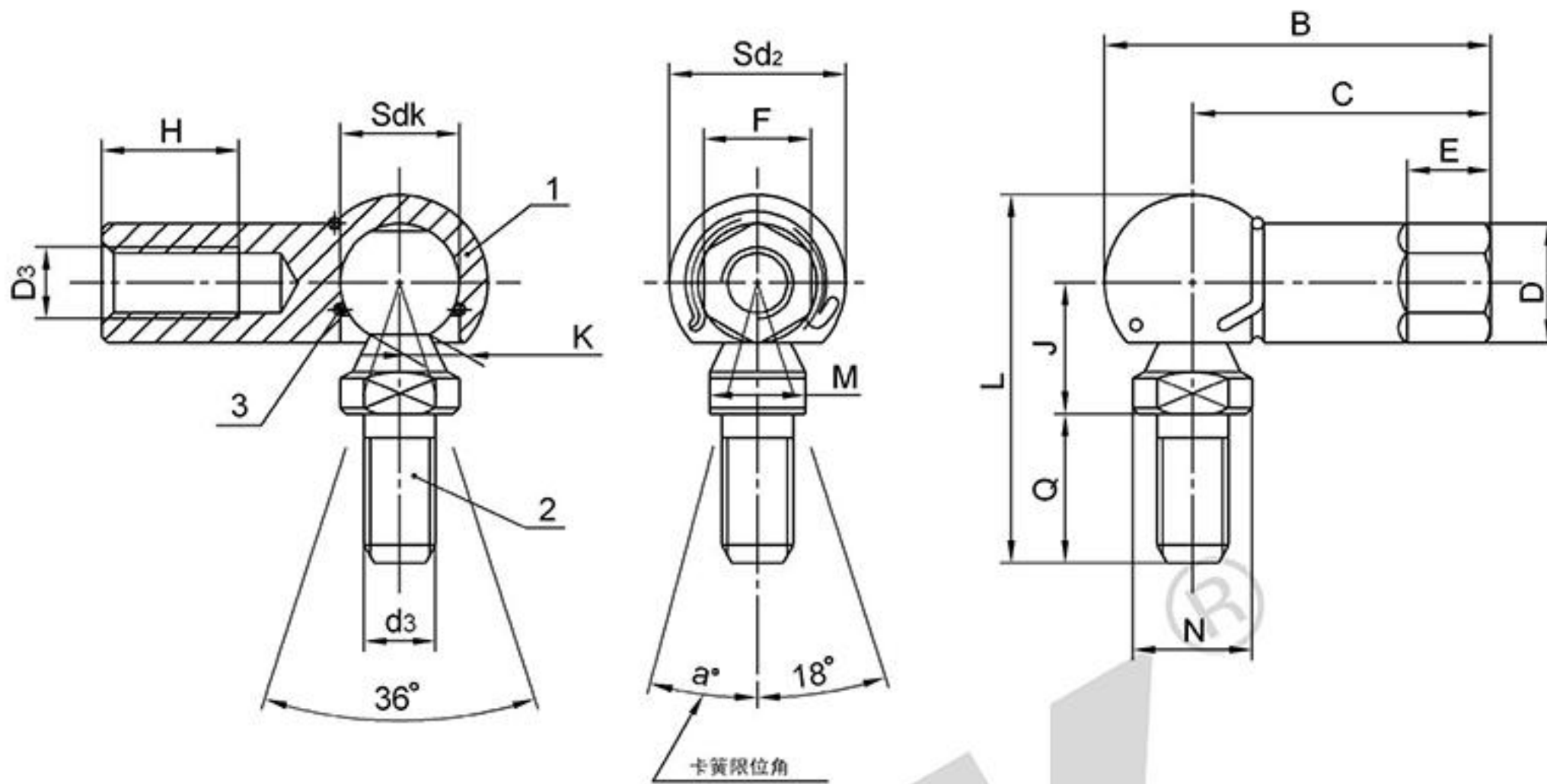

Bearing No.	Dimensions(mm)																	weight Per 100 in kg
	Sd2	H	D3	sdk	d3	K	F	M	a°	B	C	E	D	L	Q	J	N	
CS5/1	12.8	10.2	M5	8	M5	4	7	7	10	28.4	22	5	8	25.4	10.2	9	8	1.3
CS6/1	14.8	11.5	M6	10	M6	5	9	8	15	32.4	25	7	10	30.4	12.5	11	10	2.2
CS8/1	19.3	14	M8	13	M8	6.5	11	11	15	39.6	30	9	13	38.6	16.5	13	13	4.5
CS10/1	24	15.5	M10	16	M10	8	13	13	15	47	35	9	16	47	20	16	16	8.6
CS12/1	24	15.5	M12	16	M12	8	13	13	15	47	35	9	16	47	20	16	16	8.6
CS14/1	30	21.5	M14	19	M14	10	19	16	15	60	45	12	22	63	28	20	19	19.2
CS16/1	30	21.5	M16	19	M16	10	19	16	15	60	45	12	22	63	28	20	19	19.2