

## CHS..

Ball: Gcr15 Steel, heat treated, HRC58~64;  
Precision ground, polished

Body: Carbon steel, Zinc plated, chromate treated

Race: Brass, PTFE composite bonded to I.D of race

Sliding contact surfaces: Steel/PTFE composite

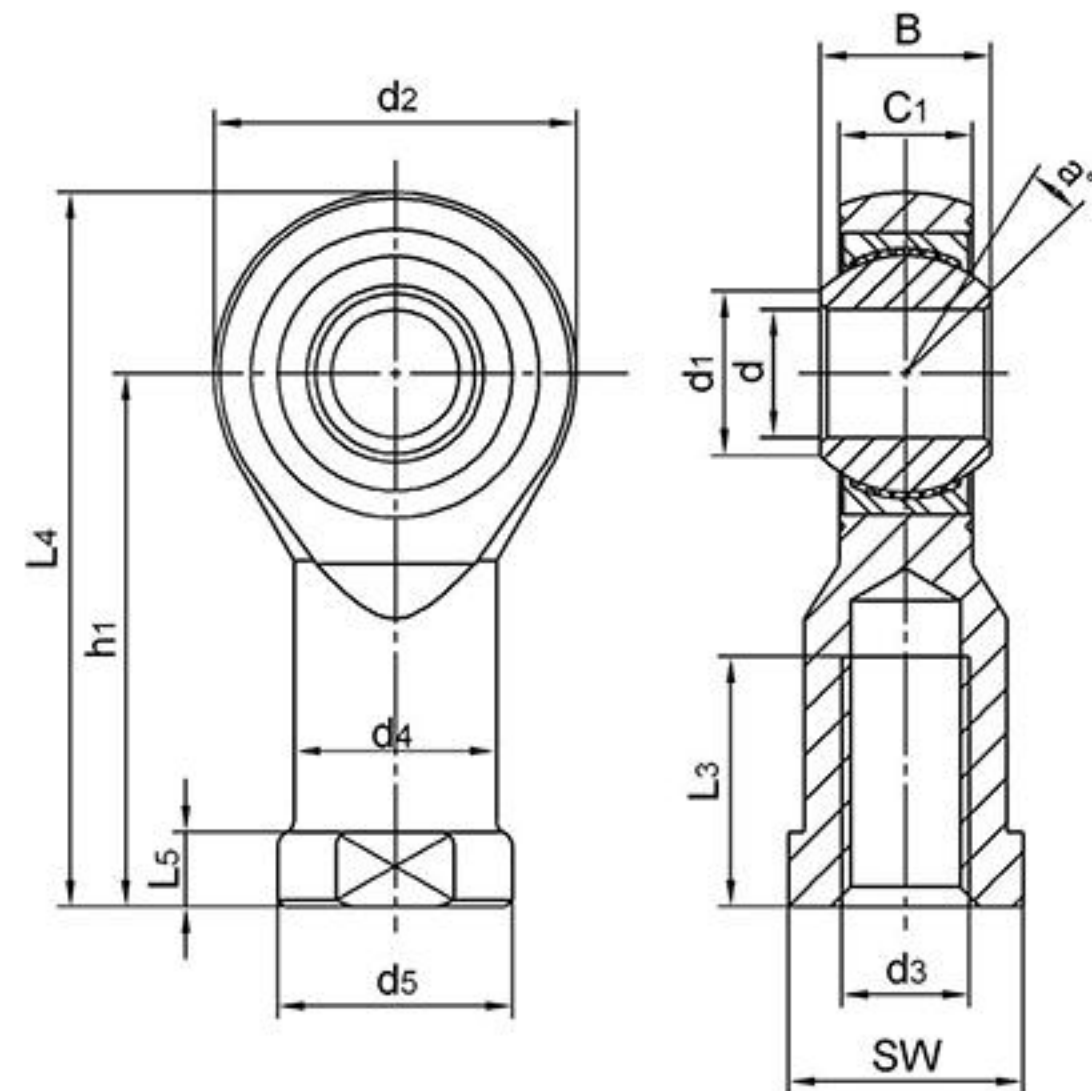

Bearing No.	Dimensions(mm)													Ball dia	a° mis. angle	Load ratings (KN)		weight ≈ Kg
	d <sub>H7</sub>	B	C1	d1	d2	d3-6H	h1	L3	(L4)	L5	d4	d5	SW			Dynamic	Static	
CHS3	3	6	4.5	5.1	14	M3	21	7	27	3	7	9	7	7.93	14	1.8	4.1	0.006
CHS4	4	7	5.25	6.5	16	M4	24	8	31	4	7.8	9.5	8	9.52	13	2.8	5.2	0.013
CHS5	5	8	6	7.7	18	M5	27	10	36	4	9	11	9	11.11	13	3.25	8	0.016
CHS6	6	9	6.75	8.9	20	M6	30	12	40	5	10	13	11	12.7	13	4.25	8.9	0.022
CHS8	8	12	9	10.3	24	M8	36	16	48	5	12.5	16	13	15.87	14	7.1	14.1	0.047
CHS10	10	14	10.5	12.9	28	M10	43	20	57	6.5	15	19	17	19.05	13	9.8	19.3	0.077
CHS12	12	16	12	15.4	32	M12	50	22	66	6.5	17.5	22	19	22.22	13	13.2	23.5	0.100
CHS14	14	19	13.5	16.8	36	M14	57	25	75	8	20	25	22	25.4	16	17	28	0.160
CHS16	16	21	15	19.3	42	M16	64	28	85	8	22	27	22	28.58	15	21.4	32	0.220
CHS18	18	23	16.5	21.8	46	M18x1.5	71	32	94	10	25	31	27	31.75	15	26	42.5	0.320
CHS20	20	25	18	24.3	50	M20x1.5	77	33	102	10	27.5	34	30	34.92	14	31	47.5	0.420
CHS22	22	28	20	25.8	54	M22x1.5	84	37	111	12	30	37	32	38.1	15	42.2	57	0.540
CHS25	25	31	22	29.5	60	M24x2	94	42	124	12	33.5	42	36	42.86	15	52.7	68	0.730
CHS28	28	35	24	32.29	66	M27x2	103	44	136	12	37	46	41	47.63	15	58.8	79	0.949
CHS30	30	37	25	34.8	70	M30x2	110	51	145	15	40	50	41	50.8	17	70.7	88	1.100

Can supply rod ends with different pitch or accuracy of thread.

For left-hand thread, suffix "L" is added to bearing numbers. eg.: CHS20L M20 x 1.5L-6H: